



## The Deputy Secretary of Energy

Washington, DC 20585

April 9, 2007

The Honorable A.J. Eggenberger  
Chairman  
Defense Nuclear Facilities Safety Board  
625 Indiana Avenue, NW, Suite 700  
Washington, D.C. 20004

Dear Mr. Chairman:

Thank you for your January 18, 2007, letter to Secretary Bodman requesting both a report and a briefing covering the following subjects: (1) the risks and priority associated with transuranic waste (TRU) operations at Los Alamos National Laboratory (LANL); (2) the pathway for shipping the above-ground high activity drums to the Waste Isolation Pilot Plant (WIPP) or actions to improve the safety posture at Area G where above-ground TRU is currently stored; and, (3) the strategy for retrieval and shipment of TRU stored below ground at LANL.

In response to the Board's request, the National Nuclear Security Administration's (NNSA) Los Alamos Site Office has worked with NNSA's contractor, Los Alamos National Security, to develop the enclosed report as well as the briefing that was provided to the Board on March 1, 2007.

NNSA and the Department of Energy recognize that a significant and timely reduction of the risks posed by the above-ground storage of TRU waste at Area G via the shipment of high activity TRU to WIPP can best be accomplished through the temporary acceptance, for one year, of increased operational risk to repackage higher activity drums at LANL's Waste Characterization, Reduction and Repackaging facility and to ship higher activity drums via the Radioassay and Non-Destructive Testing facility. These risks can be mitigated in part through the completion by LANL of proposed safety modifications to these facilities prior to the resumption of operations.

This will allow LANL to dispose of an estimated 235 out of the 325 highest risk drums by January 2008. This, combined with the lower-activity inventory scheduled for disposal, will total at least 33,000 Plutonium Equivalent Curies (PE-Ci) planned to be shipped from LANL to WIPP between October 1, 2006, and January 31, 2008. The remaining above-ground TRU waste, which will include approximately seven drums of 300-800 PE-Ci combustible, high activity TRU and 83 solids drums, will be placed in a safe storage configuration until the high activity waste stored below ground is retrieved and processed for disposition beginning in FY 2009.

If you have questions, please contact me or Mr. James McConnell, Chief, Defense Nuclear Safety for NNSA, at (202) 586-4379 or Ms. Alice Williams, NNSA's Deputy Associate Administrator for Infrastructure and Environment, at (202) 586-6847.

Sincerely,

A handwritten signature in black ink that reads "Clay Sell". The signature is written in a cursive style with a large, sweeping initial "C".

Clay Sell

Enclosure

**National Nuclear Security  
Administration Response to Defense  
Nuclear Facility Safety Board  
January 18, 2007 Letter Concerning  
Disposition of LANL High-Activity  
Transuranic Waste**

## CONTENTS

<b>EXECUTIVE SUMMARY .....</b>	<b>iii</b>
<b>1.0 INTRODUCTION .....</b>	<b>1</b>
<b>2.0 DNFSB Question #1: RISK OF HIGH-ACTIVITY TRU WASTE AT AREA G .....</b>	<b>2</b>
<b>3.0 DNFSB Question #1: TRU WASTE PROGRAM PRIORITIES .....</b>	<b>4</b>
<b>4.0 DNFSB Question #2: STRATEGY AND PATHWAY FOR SHIPPING ABOVEGROUND HIGH-ACTIVITY TRU WASTE DRUMS TO WIPP .....</b>	<b>5</b>
4.1 TRU Waste Facilities and Processing Safety Basis Strategy.....	5
4.2 WCRR Facility Modifications .....	6
4.3 RANT Modifications.....	7
4.4 TRU Waste Processing Strategy and Schedule.....	8
<b>5.0 DNFSB Question #3: STRATEGY FOR BELOWGROUND HIGH-ACTIVITY TRU WASTE SHIPMENT TO WIPP.....</b>	<b>10</b>
<b>6.0 SUMMARY .....</b>	<b>10</b>
<b>7.0 REFERENCES.....</b>	<b>11</b>

## **EXECUTIVE SUMMARY**

This report responds to a January 18, 2007 Defense Nuclear Facility Safety Board letter regarding transuranic (TRU) waste stored at Los Alamos National Laboratory (LANL). LANL has approximately 4,400 cubic meters of TRU waste stored aboveground on-site at Technical Area 54, Area G. Potential accidents that could impact this waste could result in a significant offsite dose to the public.

Approximately two percent of this waste (65 cubic meters equivalent to approximately 325 55- and 85-gallon drums) contains one third of the total aboveground activity and consequently one third of the risk to the public. Priority disposition of this “high-activity” waste has been a National Nuclear Security Administration (NNSA) priority since the Cerro Grande Fire in 2000. However, the difficulty determining and implementing the safety system upgrades necessary to process and ship this higher-activity waste has delayed its disposition to the Waste Isolation Pilot Plant. LANL plans to dispose of ~235 of the 325 highest risk, high-activity drums by January 2008 – this, combined with the lower-activity transuranic drums scheduled for disposal, will reduce the aboveground activity at Area G by 33,000 plutonium-equivalent Curies. The remaining ~90 drums require additional processing capabilities that will be implemented after FY 2008. Until then, these drums will be placed in a safe storage configuration. The number of high-activity drums should be considered approximate or nominal and is based on historical data. The number will be revised as these drums are processed and the historical record replaced with certified measurements. This report summarizes NNSA’s strategy and path forward for disposition of aboveground high-activity TRU waste and NNSA’s strategy for minimizing risk during disposition of belowground TRU waste.

## 1.0 INTRODUCTION

This report is the Department of Energy - National Nuclear Security Agency's (DOE-NNSA) response to the January 18, 2007 letter from the Defense Nuclear Facilities Safety Board (DNFSB) Chairman A. J. Eggenberger to Secretary of Energy Samuel Bodman in which the DNFSB requests information about risks, priorities, and disposition pathway strategies for high-activity transuranic (TRU) waste stored at Los Alamos National Laboratory's (LANL) Technical Area (TA) 54, Area G. Specifically, DNFSB requested a report and briefing describing:

- (1) risks and priority associated with LANL TRU waste operations,
- (2) either a timely pathway for shipping the aboveground high-activity drums to the Waste Isolation Pilot Plant (WIPP) or urgent actions to improve the current safety posture at Area G, and
- (3) a prudent strategy for shipping additional TRU waste that will be retrieved from underground storage in the future.

As of October 1, 2006, LANL had 4,424 cubic meters (119,000 plutonium-equivalent Curies [PE-Ci]) of TRU waste stored aboveground in fabric domes and Conex containers and another 2,438 cubic meters (110,890 PE-Ci) stored belowground in pits and shafts at Area G (see Ref. 1). Three hundred twenty-five (325) of the aboveground drums (2% of the total volume) contain one third of the aboveground activity. LANL's TRU waste is being dispositioned to WIPP with completion scheduled in 2012. This allows time for Material Disposal Area (MDA) G (within Area G) to be closed by 2015 in compliance with the Consent Order effective March 1, 2005.

Area G is situated on the eastern edge of the LANL site, 250 meters from the western edge of the San Ildefonso Indian Pueblo land and 1.3 miles from the community of White Rock (see Figure 1). Several of the accident scenarios at Area G, such as seismic events, wildfires, etc., could result in radiation releases that would impact the neighboring communities. To reduce the risk this waste poses to the public, the NNSA has made timely disposition of the highest-activity aboveground TRU waste a priority. These drums contain activity >56 PE-Ci; therefore, processing them requires accepting increased operations risk to repackage higher-activity drums at the Waste Characterization, Reduction, and Repackaging (WCRR) facility and to ship higher activity drums via the Radioassay and Non-Destructive Testing (RANT) facility to WIPP. This report describes NNSA's path forward for implementing this priority.

The remainder of the report is organized into sections describing risk, TRU Waste Program priorities, timely disposition pathway for aboveground high-activity TRU waste, strategy for disposition of belowground high-activity TRU waste, and a summary.

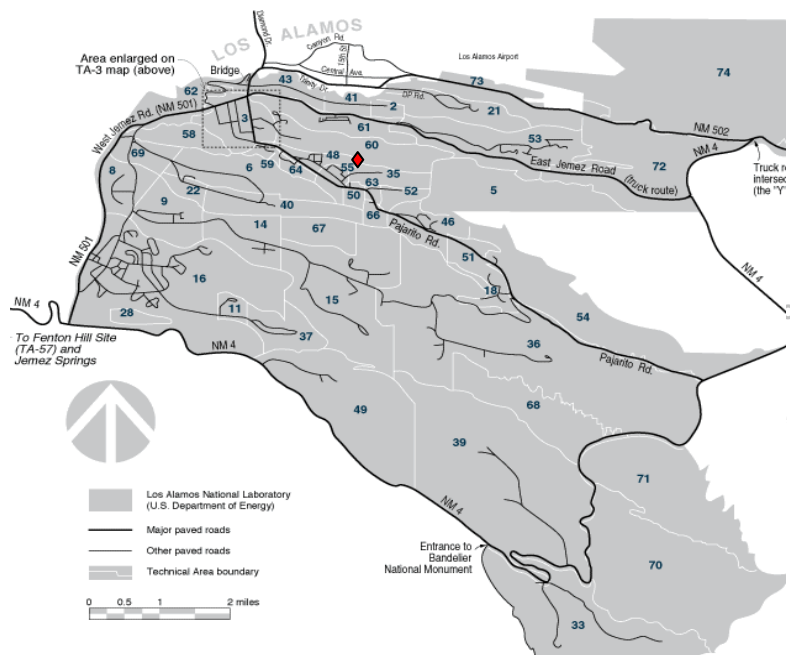

325 high-activity aboveground drums account for about one third of the Area G aboveground activity (Material at Risk)

High-activity TRU drums contain >56 PE-Ci

Figure 1. LANL Site Map

## 2.0 DNFSB QUESTION 1: RISK OF HIGH-ACTIVITY TRU WASTE AT AREA G

The current aboveground activity of TRU waste at Area G is approximately 119,000 PE-Ci. Approximately one third of this activity is contained in 325 drums. These drums are referred to as the “high-activity” or “high-material-at-risk (MAR)” drums. They each contain between 56 PE-Ci and 800 PE-Ci of TRU waste. Most of these drums require processing and repackaging to meet WIPP Waste Acceptance Criteria; the WCRR facility does not have the authorization to process and repackage containers with greater than 56 PE-Ci under its current safety basis. Additionally, LANL’s ability to load TRU waste containers into TRUPACT-II and/or Half-PACT packages for shipment to WIPP is limited because the RANT facility’s MAR is limited to 233 PE-Ci. It is proposed that the MAR limit in the WCRR and RANT facilities be increased to process and repackage these containers and facilitate shipment to WIPP.

Figure 1, above, shows the location of WCRR, RANT, and Area G in relation to LANL’s site boundary (shaded area). Area G is located closest to the site boundary and has the highest source term to dose conversion factors for calculating potential off-site consequences. WCRR is the furthest from the site boundary and has the lowest source term to dose conversion factors for calculating potential off-site consequences.

To evaluate the proposed WCRR/RANT MAR increase, a comparison of relative risks at Area G versus WCRR and RANT was prepared and is provided as Reference 2. This analysis considered the evaluation basis accidents in the current approved Area G Documented Safety Analysis (DSA) and the

proposed DSAs for WCRR and RANT. Fire is the highest consequence accident scenario. The consequences and likelihood for each evaluation basis accident were used in the analysis to determine the relative risk of each facility at both current approved MAR limits and the proposed increased MAR limits. The consequences were normalized by using International Commission on Radiological Protection (ICRP) 68/72 dose conversion factors for all accidents in this risk comparison. The MAR assumptions are as follows:

- For Area G, the current aboveground MAR inventory of 119,000 PE-Ci was used as the base case and 86,000 PE-Ci was used as the subsequent MAR assuming 33,000 PE-Ci are shipped to WIPP within the next twelve months.
- For WCRR, the current MAR limits of 56 PE-Ci in the building and 1,000 PE-Ci total site were used as the base case and 300 PE-Ci combustible equivalent waste in the building and 1,800 PE-Ci total site were used as the high-MAR case for a twelve month duration. (Note: the combustible-equivalent waste concept is used here to indicate that 300 PE-Ci of combustible waste represents approximately the same level of risk as 800 PE-Ci of non-combustible waste.)
- For RANT, the current MAR limits of 233 PE-Ci in the building and 3,680 PE-Ci total site were used as the base case and 1,800 PE-Ci in the building and 3,680 PE-Ci total site were used as the high-MAR case for a twelve month duration.

The relative unmitigated risk increases at WCRR and RANT for one year while high-MAR drums are processed. The relative unmitigated risk is reduced permanently at Area G through the removal of aboveground drums. Comparatively, the relative risk at Area G decreases by 6.2 rem/year while the relative risk at WCRR and RANT is increased by 4.9 rem/year and 2.2 rem/yr respectively for unmitigated consequences and frequencies. For mitigated consequences and frequencies, the relative risk at Area G decreases by 0.7 rem/year while the relative risk at WCRR and RANT is increased by 0.01 rem/year and 0.09 rem/yr respectively. This demonstrates that during the first year, the increased relative risk at WCRR and RANT is offset by the reduced relative risk at Area G for the mitigated case, but the relative risk is slightly increased for the unmitigated case. In subsequent years when WCRR and RANT are not processing high-activity drums, the risk is substantially less in both cases (see reference 2). In conclusion, the multi-year risk associated with approving higher MAR limits at WCRR is less than the risk associated with continued storage at Area G. Table 1 provides a summary of the first year relative risk analysis.



**Table 1. Summary of the Relative Risk Analysis**

DSA Area	Unmitigated Relative Risk (rem/yr) <sup>a</sup>		Mitigated Relative Risk (rem/yr) <sup>a</sup>		Primary Controls/Confidence Level
	Risk With Current MAR Limits (rem/yr)	Risk With Proposed MAR Limits (rem/yr)	Risk With Current MAR Limits (rem/yr)	Risk With Proposed MAR Limits (rem/yr)	
Area G	21.4	15.2	4.7	4.0	<b>Area G</b> – Existing Controls <ul style="list-style-type: none"> <li>• Drums (SC, Medium)</li> <li>• Domes (SC, Low)</li> </ul> <b>WCRR</b> – Proposed Controls <ul style="list-style-type: none"> <li>• Vehicle Barriers (SC, High)</li> <li>• Fuel Controls (SC, High)</li> </ul> <b>RANT</b> - Proposed Controls <ul style="list-style-type: none"> <li>• Vehicle Barriers (SC, High)</li> <li>• Fuel Controls (SC, High)</li> <li>• Lifting Devices (SS, Medium)</li> </ul>
WCRR	5.2	10.1	0.05	0.06	
RANT	0.8	3.0	0.02	0.11	

<sup>a</sup> “Comparison of Relative Risks at TA-54 Area G and the TA-50 Waste Characterization Repackaging Reduction Facility,” Antonio Villegas, February 2007. (Ref. 2)

**3.0 DNFSB QUESTION 1: TRU WASTE PROGRAM PRIORITIES**

The mission of the TRU Waste Program is to disposition TRU waste stored at Area G and newly generated solid TRU waste being produced by TA-55, the Radioactive Liquid Waste Treatment Facility, and other LANL mission operations. The first priority of the TRU Waste Program is to reduce the risk to the public by shipping the highest-activity waste. This priority will be implemented by immediate disposition of 235 of the 325 high-activity drums to WIPP by January 31, 2008. These drums, because of their high activity and in some cases, the presence of prohibited items, must be opened, have the prohibited items addressed, and be repackaged in a glovebox in the WCRR facility. The remaining 90 high-activity drums will be placed in a safe storage configuration so their contribution to the Area G risk is minimized. These will be disposed to WIPP over the next 2-4 years as additional key drum processing or characterization capabilities are implemented. The campaign to disposition a large number of the high-activity drums will significantly reduce the aboveground MAR in a relatively short period of time. In addition, LANL will increase the shipping rate of low-activity TRU drums from 3 to 4 WIPP shipments per week.

The second priority for the TRU Waste Program is the expeditious disposition of newly generated waste. This focus has been to assure that newly generated waste can transit through the WIPP certification process with minimum residence time at Area G. This process assumes and requires that the newly generated waste received at Area G is fully compliant with the WIPP packaging requirements and contains no prohibited items.

A third priority is to assure that wastes are packaged so as to maximize the waste per container, to minimize the containers requiring disposition and shipment to WIPP, and to conserve WIPP disposal volume. Additionally, LANL must develop a backlog of lower-activity wastes ready to ship to WIPP to maximize and optimize the number of containers in each WIPP shipment.

The fourth priority is to optimize the use of TRU waste repackaging facilities (WCRR, Dome 231, and Decontamination and Volume Reduction System). This optimization includes the efficient use of personnel (shift schedules) and the flexibility to address multiple waste types in a given facility within its approved safety basis. In particular, the remediation of prohibited items has proven to be a major limitation for the efficient disposition of TRU waste. Multiple shifts and multiple facilities are required to maintain an adequate certified waste backlog to meet the closure schedule for Area G.

**4.0 DNFSB QUESTION 2: STRATEGY AND PATHWAY FOR SHIPPING ABOVEGROUND HIGH-ACTIVITY TRU WASTE DRUMS TO WIPP OR URGENT ACTIONS TO IMPROVE THE CURRENT SAFETY POSTURE AT AREA G**

Facility modifications at the WCRR and RANT facilities, consistent with safety basis authorization, must be completed and readiness/authorization authority achieved to allow for the processing, repackaging, and shipment of high-activity drums to WIPP (see schedule in Figure 2). Once WCRR/RANT operating authority is received, 235 of the 325 high-activity drums will be dispositioned to WIPP by January 31, 2008; the remaining drums will be placed in a safe storage configuration that minimizes the risk to the public. Once WCRR/RANT modifications and readiness assessments are completed, high-activity drums will be processed and shipped according to the TRU Waste Program schedule. Shipment of high-activity waste has been coordinated with the Carlsbad Field Office which will provide characterization, certification, and transportation services for this waste. The following sections provide specific information on the safety basis strategy, modifications to WCRR and RANT facilities, safe storage, and drum disposition.

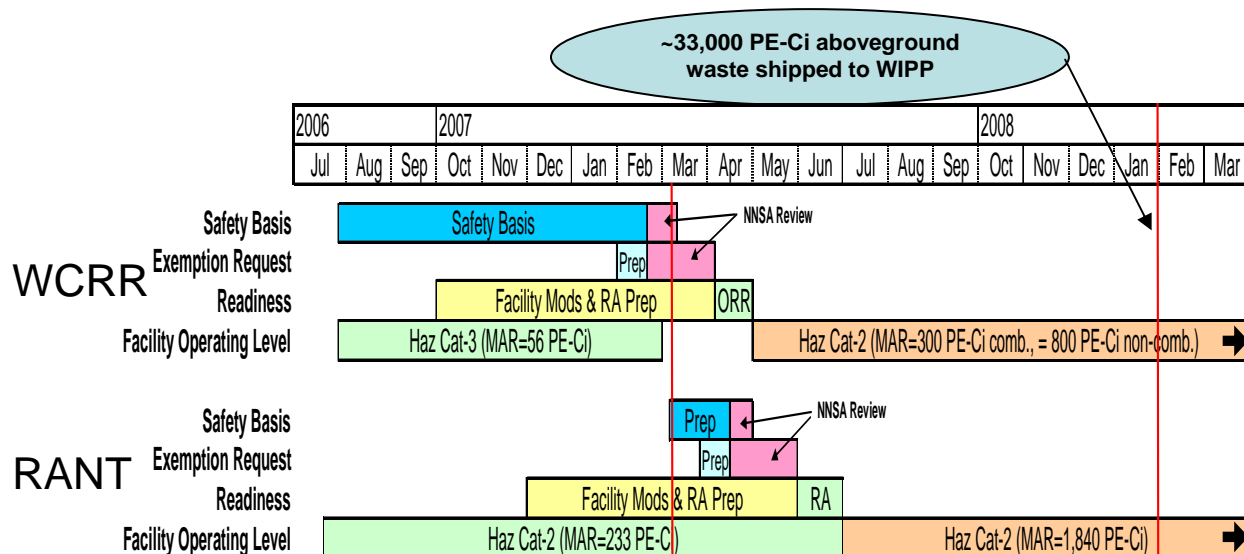

Figure 2. WCRR and RANT Project Management Plan Schedule (Ref. 3)

**4.1 TRU Waste Facilities and Processing Safety Basis Strategy**

LANL has developed a DOE-Los Alamos Site Office (LASO)-approved Safety Basis Improvement Plan. Included in this plan is an aggressive two-year schedule to develop Title 10 Code of Federal Regulations

(CFR) 830 Subpart B-compliant safety bases for all LANL Hazard Category 2 and 3 Nuclear Facilities. In addition, procedures used for development of safety bases are being upgraded to current standards and expectations.

Upgrading of the WCRR and RANT safety bases is one of the highest priorities of the LANL Safety Basis Improvement Plan. Proposed safety bases for WCRR and RANT were submitted to LASO in November 2006. LASO performed a preliminary review of these safety bases and provided a set of comments. Resolution of these preliminary comments between LASO and LANL is ongoing and the comments that have been resolved will be built into the Basis for Interim Operations/Technical Safety Requirements (BIO/TSR) that are proposed for temporary operations under an exemption to 10 CFR 830 with NA-10 Authorization. The exemption relief request is only for operation of WCRR and RANT without an approved Safety Evaluation Report (SER) to expedite shipment of TRU Waste while an approved SER is prepared. LANL will continue to pursue an approved SER in parallel with operation under exemption relief. . The exemption relief will allow processing of aboveground high-MAR TRU waste through WCRR and RANT while the compliant BIO/TSRs are completed, approved, and implemented. The proposed exemption relief will expire upon completion of the processing of specified aboveground high-MAR TRU waste or implementation of the compliant BIO/TSRs. After that time, the facility will transition to operation of RANT and WCRR under the newly approved compliant BIO/TSRs.

#### **4.2 WCRR Facility Modifications**

The WCRR facility was originally constructed in the early 1980s to provide size reduction and handling of low-level waste. As part of the efforts to repack high-activity TRU waste containers(>56 PE-Ci) for shipment to WIPP, various areas associated with WCRR operations for TRU waste have been reviewed to identify items required to ensure safe operations. These items include several facility modifications that will be performed prior to processing high-activity drums. Depicted in Figure 2, above, the "Facility Mods & RA Prep" activity includes the following items as detailed in the Integrated Project Management Plan (Ref. 3):

- Seismic Modifications – complete structural improvements to increase the facility's ability to withstand seismic loads
- Fire Suppression – upgrade fire suppression system to meet Ordinary Hazard Group 2 criteria and to reduce sprinkler head actuation temperature
- Natural Gas Elimination – remove the natural gas supply to the facility
- Vehicle Barriers – provide a vehicle barrier system to prevent an errant vehicle from impacting the facility or any stored drums at the site
- Drum Staging – establish designated protected waste storage areas

- Wild Land Fire Exclusion Zone – expand fire breaks to reduce the risk from a wild land fire
- Lightning Protection – upgrade lightning protection system to meet National Fire Protection Association (NFPA) Standard 780

Also, as part of the change to operations involving high-activity drums of TRU waste, necessary maintenance items have been reviewed and scoped. Maintenance items include ensuring that all necessary core corrective and preventive maintenance has been performed, replacing high-efficiency particulate air filters, removing excess equipment and non-functional equipment, and ensuring the facility has clean surface areas that support decontamination, if required. Also, as part of the change to operations, facility system assessments are being conducted in accordance with the Integrated Project Management Plan. These assessments will identify any risk reduction actions that will be taken prior to operations. Finally, any equipment (e.g., non-propane forklifts, containers, etc.) required to support the high-activity drum operations will be identified and criteria, schedule, and control of the items established.

The above WCRR facility modifications and upgrades will allow for the processing and repackaging of combustible TRU waste up to 300 PE-Ci and non-combustible TRU waste up to 800 PE-Ci. Some work can occur during the pre-outage period on maintenance weekends that does not interfere with ongoing operations. Facility modifications have been scheduled during a formal facility outage in March 2007 and will be completed by the end of that month. DOE Order 425.1C requires a Contractor Operational Readiness Review (ORR) prior to a DOE ORR. An exemption to this order is being requested to conduct an NNSA ORR without a Contractor ORR based on the risk-based urgency to commence waste operations at the WCRR facility. The formal NNSA ORR will be conducted in April 2007. ORR pre- and post-start items will be dispositioned according to the requirements of the order.

#### **4.3 RANT Modifications**

The RANT facility was designed and constructed between the 1987 and 1988 time frame and originally supported radioassay and nondestructive testing. Currently, the facility supports the loading of TRUPACT-II/Half-PACT containers for shipment to WIPP. As part of the preparation for handling high-activity drums for shipment to WIPP, various areas associated with RANT operations have been reviewed to ensure safe operations. Depicted in Figure 2, above, the “Facility Mods & RA Prep” activity includes several facility modifications that will be performed prior to processing high-activity drums at the facility, including:

- Fire Suppression – upgrade fire suppression system to reduce sprinkler head actuation temperature
- Vehicle Barriers – provide a vehicle barrier system to prevent an errant vehicle from impacting the facility or any stored drums at the site
- Drum Staging – establish designated protected waste storage areas

- Wild Land Fire Exclusion Zone – expand fire breaks to reduce the risk from a wild land fire
- Lightning Protection – upgrade lightning protection system to meet NFPA Standard 780

Necessary corrective and preventive maintenance items have been reviewed and scoped. System assessments are being performed in accordance with the Integrated Project Management Plan. The above RANT facility modifications and upgrades will allow for the loading and shipping of high-activity TRU waste containers in RANT at a MAR limit of 1,840 PE-Ci. The RANT facility modifications will be completed by the end of May 2007. Existing DOE Order 425.1C requirements will be followed for readiness review of the RANT facility. LANL has recommended to NNSA/LASO that a Laboratory Readiness Assessment be conducted with NNSA start-up/restart authorization authority.

#### **4.4 TRU Waste Processing Strategy and Schedule**

##### **Disposition of Aboveground 56 - 300 PE-Ci Combustible Debris and Non-Combustible Debris Up to 800 PE-Ci**

The summary strategy for processing, characterizing, and shipping the aboveground high-activity TRU waste is presented below. The starting point for this series of activities is authorization of the WCRR facility to operate at the >56 PE-Ci MAR level, scheduled on or about April 30, 2007; however, significant preparatory work to perform initial characterization and to stage the inventory at Area G for transfer to the WCRR facility will occur prior to April 30, 2007. The scope of these activities encompasses the processing and disposal of approximately 235 of the 325 high-activity drums, that when combined with lower-activity inventory scheduled for disposal will total at least 33,000 PE-Ci shipped to WIPP between October 1, 2006 and January 31, 2008. This effort will be facilitated by dividing the aboveground drums into discrete populations for processing at the WCRR facility (populations comprising like waste matrices, contents, activities, etc.). A waste processing instruction will be prepared for each container to guide waste remediation/repackaging activities. This instruction will include a procedure for determining how many daughter drums will result from each repackaging activity.

##### **Disposition of Aboveground 300 - 800 PE-Ci Combustible TRU Waste**

The disposition of the ~seven aboveground 300 - 800 PE-Ci high-activity combustible TRU waste will be deferred until the belowground inventory is processed so that above-and belowground 300-800 PE-Ci drums can be addressed by a single campaign in the FY 2009-2010 timeframe. Until then these containers will be placed in a safe storage configuration. LANL will overpack these containers into standard waste boxes, evaluate several safe storage configurations (e.g., overpack, concrete vaults, or belowground shafts) and select the most appropriate by May 1, 2007.

##### **Disposition of Aboveground Monolithic Drums and Drums with Small Internal Containers of Solids**

The solids drums with internal containers cannot be characterized and shipped to WIPP until capability to sample and analyze them has been developed. This capability is required to satisfy the WIPP characterization requirements of the WIPP Resource Conservation Recovery Act permit. Several of the monolithic solids drums (a 55-gallon drum filled with cemented sludge) must be repackaged into two or more daughter drums because they exceed the 225 PE-Ci calibration limit of the Non-Destructive Assay instrument. The current population of internal-cans and monolithic drums consists of approximately 83 drums. Disposition of this population will be deferred until the FY 2009-2010 time frame when characterization and repackaging capabilities are expected to have been implemented for these waste forms. Since these drums consist of cemented, or otherwise solid, non-dispersible waste, their contribution to the risk is much less than for combustible waste drums of equivalent activity. Consequently, these solids drums can be safely stored aboveground. Table 2 summarizes the above- and belowground drums for which disposal is being deferred.

Table 2. Deferred disposition waste

Waste Form	Above-ground	Below-ground	Safe Storage	Critical Disposition Step
<u>Combustibles Drums</u> 300-800 PE-Ci	~7 drums ~3,533 PE-Ci	~53 drums ~31,300 PE-Ci	Overpack aboveground drums into standard waste boxes and select an interim storage configuration by May 1, 2007	Repackaging: FY09-10 1. WCRR (after upgrade) 2. Other LANL facility 3. Mobile Repack Unit 4. 40CFR Part 191 disposal at LANL
<u>Solids Drums</u> Internal Cans	~83 drums ~15,351 PE-Ci	~115 drums ~13,400 PE-Ci	Above ground; solid form is non-dispersible, minimal contribution to aboveground risk	RCRA Sampling: FY09 1. Implement CCP-approved procedure at LANL (similar to RF procedure) 2. Implement procedure at another site
<u>Solids Drums</u> Monolithics				Fracture/Repackaging: FY09-10 Break-up monoliths at WCRR or Dome 231 (using RF procedure)

At this point, all but 10 of the 325 high-activity drums have completed pre-screened characterization, 19 drums have been certified for shipment, and 12 drums have been shipped to WIPP.

## **5.0 DNFSB QUESTION 3: STRATEGY FOR BELOWGROUND HIGH-ACTIVITY TRU WASTE SHIPMENT TO WIPP**

Trenches A-D contain >95% of the belowground high-activity waste; Pit-9 contains the remainder. Trenches A-D waste consists of up to two 30-gallon drums in each of 363 concrete casks; approximately half of these drums have activity exceeding 56 PE-Ci. A staged approach for waste retrieval will be synchronized with characterization and shipping activities. Waste will remain in these below ground vaults until it is to be characterized, thus minimizing the aboveground MAR at any one time. The retrieval schedule for trench A-D and Pit-9 waste will be determined by funding availability. Approximately 220 drums of belowground high-activity (56 PE-Ci to 300 PE-Ci) combustible TRU waste will be repackaged at WCRR and shipped from RANT using the same process as for the aboveground high-activity drums.

### **Disposition of Belowground 300-800 PE-Ci Combustible TRU Waste**

The retrieval of the 300-800 PE-Ci combustible high-activity TRU waste will be deferred until the FY 2009-2010 time frame when repackaging or on-site disposal options are expected to be available. This TRU waste population is ~53 drums. The strategy for this waste is to evaluate repackaging options that will enable the timely shipment of this waste offsite. The repackaging capabilities of WCRR will be re-evaluated to determine if the facility can be used to process these drums. Other options will be considered including the possibility of leaving these waste containers in place per 40 CFR Part 191 or repackaging these drums in a mobile repacking facility or at another LANL facility.

### **Disposition of Belowground Monolithic Drums and Drums with Small Internal Containers of Solids**

Retrieval of the approximately 115 drums containing monolithic solids and small internal containers of solids will be deferred until FY 2009-2010 timeframe when repackaging and characterization capabilities or on-site disposal options are expected to have been developed and implemented. This approach will also be used for the same aboveground waste type.

## **6.0 SUMMARY**

The NNSA has established a strategy for quickly disposing of the highest-activity TRU waste that currently represents the greatest risk to the neighboring public. This strategy effectively addresses safety basis, facility, and operational requirements. It is based on balancing the aboveground storage risk and the processing and shipping risk.

NNSA is committed to the following:

- disposing of 33,000 PE-Ci within the next twelve months by expediting disposition of 235 high-activity aboveground drums by January 31, 2008,

- staging belowground waste so that aboveground MAR and consequent risk to the public are minimized, and
- implementing risk reduction without adversely impacting the Program's mission objective of completing TRU waste disposition by 2012 to meet the NMED Consent Order schedule for closure of MDA G (part of Area G) by 2015.

Of the highest-activity drums, 12 have already been shipped and 19 more are ready to be shipped.

Expeditious disposition of the highest-activity aboveground drums is the TRU Waste Program's highest priority. This priority has been integrated with the program's other priorities so that it can be accomplished with minimum disruption to the overall Program Mission.

## 7.0 REFERENCES

1. For purposes of MAR calculation, the initial belowground total activity value is corrected for radioactive decay to 93,000 PE-Ci.
2. Villegas, Antonio, 2007. LA-UR-07-1164, "Comparison of Relative Risks at TA-54-Area G and the TA-50 Waste Characterization Repackaging Reduction Facility," Los Alamos National Laboratory, Los Alamos, New Mexico.
3. Zerkle, Carolyn, 2007. "Disposition of Transuranic Waste at Los Alamos National Laboratory, Integrated Project Management Plan," Los Alamos National Laboratory, Los Alamos, New Mexico.