



Department of Energy
Washington, DC 20585

NOV 30 2005

The Honorable A. J. Eggenberger
Chairman
Defense Nuclear Facilities Safety Board
625 Indiana Avenue, N.W., Suite 700
Washington, DC 20004-2901

Dear Mr. Chairman:

I am forwarding you the enclosed Office of Environmental Management (EM) Quality Assurance Program Plan (QAPP) that demonstrates satisfactory completion of Commitment 10A in the Department's 2004-1 Implementation Plan for *Oversight of Complex, High-Hazard Nuclear Operations*.

The deliverable for this commitment also calls for "approved paths forward and schedules for achieving full implementation, including revision and implementation of field element QAPs." The EM QAPP will be fully implemented within 1 year, including completion of applicable training. Currently, all EM Field Offices have approved QAPs but because of the timing of these approvals, most are written to Department of Energy (DOE) O 414.1B and two are written to the latest revision, DOE O 414.1C. All EM Field Office QAPs will be updated to be compliant with DOE O 414.1C by March 2006. After updating to the latest revision, completion of implementation at Field Offices will be achieved within 6 months.

If you have any comments or feedback, please call me at (202) 586-0738 or Mr. Dae Y. Chung, Acting Deputy Assistant Secretary for Integrated Safety Management and Operations Oversight, at (202) 586-5151.

Sincerely,

A handwritten signature in black ink that reads "Inés R. Triay".

Dr. Inés R. Triay
Chief Operating Officer for
Environmental Management

Enclosure

cc: Mark B. Whitaker, Jr., DR-1





Department of Energy

Washington, DC 20585

November 23, 2005

MEMORANDUM FOR DISTRIBUTION

FROM:

JAMES A. RISPOLI
ASSISTANT SECRETARY FOR
ENVIRONMENTAL MANAGEMENT

A handwritten signature in black ink, appearing to read "JA Rispoli".

SUBJECT:

Issuance and Implementation of the Office of
Environmental Management Quality Assurance Program
Plan

The Office of Environmental Management (EM) Headquarters (HQ) has developed our Quality Assurance Program Plan (QAPP), which meets the intent of the Department of Energy (DOE) Quality Assurance Order (DOE O 414.1C). This plan lays out my expectations and goals for an effective Quality Assurance (QA) Program at EM-HQ. It is attached for your immediate use.

I ask that you support this plan by 1) implementing its requirements and 2) embracing and applying QA principles in every activity you and your organization performs for EM. Please provide any lessons learned during implementation of the EM-HQ QAPP to the EM-3.2 Deputy Assistant Secretary so our QA Program and Plan can be continuously improved.

The mandatory training, in development by EM Headquarters, on the implementation of the EM-HQ QA Program and the specialized QA training for EM Managers and selected technical staff must be completed, as applicable, within one year from the date of this memorandum. Please ensure you encourage and allow for completion of this training for both you and your staff.

If you have any further questions, please call me at (202) 586-7709 or Dae Y. Chung, Acting Deputy Assistant Secretary for Integrated Safety Management and Operations Oversight, at (202) 586-5151.

Attachment



Distribution

Charles Anderson, Principal Deputy Assistant Secretary, EM-2

Dr. Inés Triay, Chief Operating Officer, EM-3

Dae Chung, Acting Deputy Assistant Secretary for Integrated Safety
Management/Operations Oversight, EM-3.2

Frank Marcinowski, Deputy Assistant Secretary for Logistics and Waste Disposition
Enhancements, EM-10

Mark Gilbertson, Deputy Assistant Secretary for Environmental Cleanup and
Acceleration, EM-20

Mark Frei, Deputy Assistant Secretary for Business Operations, EM-30

James Fiore, Acting Deputy Assistant Secretary for Performance Intelligence and
Improvement, EM-40

cc:

Jack Craig, CBC
Gerald Boyd, OR
Elizabeth Sellers, ID
Robert Warther, OH
Keith Klein, RL
Roy Schepens, ORP
Frazer Lockhart, RFPO
Jeffrey Allison, SR
Lloyd Piper, CBFO
William Murphie, PPO
Rodrigo Rimando, Jr., BNL
Richard Provencher, ID
Stephen McCracken, OR
Maurice Daugherty, EM-3.1
Ray Lopiccolo, EM-3.1
Colette Broussard, EM-3.2
Sandra Johnson, EM-3.4
Richard Dailey, EM-3.4
Eric Huang, EM-11
Dennis Ashworth, EM-11
Christine Gelles, EM-12
Cynthia Anderson, EM-13
Sandra Waisley, EM-21
Lawrence Bailey, EM-22
Dr. Robert Goldsmith, EM-23
Randal Kaltreider, EM-24
Linda Suttora, EM-24
Melissa Nielson, EM-30.1
Barbara Heffernan, EM-31
Karen Guevara, EM-32
Ronald Smith, EM-33
Joni Boone, EM-33
Jaffer Mohiuddin, EM-40
Diane Cochran, EM-41
Barry Smith, EM-42
Jay Rhoderick, EM-43
Chip Lagdon, CSN-ESE
Frank Tooper, EH-32
Robert Loesch, EH-31
Gustave Danielson, EH-31
Rabindra Singh, NA-124
Mark Janaskie, NE-70
Matthew Cole, SC-31.1

Quality Assurance Program Plan

Office of Environmental Management Headquarters



Department of Energy

November 15, 2005

Table of Contents

Acronyms iii

1. Introduction..... 1

 1.1 Mission 1

 1.2 Policies and Management Principles 1

 1.3 Linkage Between Integrated Safety Management and Quality Assurance at EM-HQ 1

2. EM-HQ Quality Assurance (QA) Implementation Overview 3

3. EM-HQ Organization..... 4

 3.1 DOE-EM Interfaces 4

 3.2 National, Tribal and International Interfaces 5

4. Line Management of EM QA 6

 4.1 QA Flowdown 6

 4.2 EM QA Administrator 7

 4.3 Field Interactions 7

 4.4 Deficiency Resolution..... 9

5. Nuclear Safety Requirements..... 10

 5.1 NQA-1 and 10 CFR 830 Implementation at Headquarters..... 10

 5.2 Nuclear Safety-Related Activities at EM-HQ (10 CFR 830 related)..... 10

 5.3 NQA-1 Implementation at Headquarters 11

 5.4 Project QA Plans..... 11

6. Software Quality Assurance at EM-HQ..... 14

 6.1 EM-HQ Software subject to NQA-1 or 10 CFR 830..... 14

 6.2 Implementation of Software Quality Assurance at EM-HQ 14

7. Management and Administrative Quality Assurance 15

 7.1 Criterion 1: Program 15

 7.2 Criterion 2: Personnel Training and Qualification..... 15

 7.3 Criterion 3: Quality Improvement 20

 7.4 Criterion 4: Documents and Records 21

 7.5 Criterion 5: Work Processes 22

 7.6 Criterion 6: Design..... 24

 7.7 Criterion 7: Procurement 24

 7.8 Criterion 8: Inspection and Acceptance Testing 24

 7.9 Criterion 9: Management Assessments..... 25

 7.10 Criterion 10: Independent Assessments..... 26

Appendix A – EM Management Tools..... 27

Appendix B – Graded Approach 31

 B.1 Graded Approach Requirement..... 31

 B.2 Factors in Applying the Graded Approach..... 31

 B.3 Applying the Graded Approach at EM-HQ 31

Tables

Table 1 – Criteria for Project QA Plan.....14
Table 2 – Quality Assurance at EM-HQ for other than NQA-1 or 10 CFR 830 Related Activities18
Table 3 – EM-HQ Management Tools.....28

Figures

Figure 1 – EM Headquarters Organizational Chart.....6
Figure 2 – QA Functional Relationships.....7
Figure 3 – Procedure Improvement Process From Lessons Learned.....22

DOE EM-HQ Quality Assurance Program Plan

ACRONYMS

ATMS	Automated Transportation Management System
BNL	Brookhaven National Laboratory (Brookhaven Completion Project Office)
CAIRS	Computerized Accident/Incident Reporting System
CAM	Corrective Action Management
CAMP	Corrective Action Management Plan
CAP	Corrective Action Plan
CATS	Corrective Action Tracking System
CBFO	DOE Carlsbad Field Office
CCB	Configuration Control Board
CF	Department of Energy Chief Financial Officer
CFR	Code of Federal Regulations
CMAC	Contract Management Advisory Council
COO	Chief Operating Officer
CSO	Cognizant Secretarial Office(r)
CTA	Central Technical Authority
CRAD	Criteria Review and Approach Document
D&D	Decontamination and Decommissioning (also Deactivation and Decommissioning)
DAS	Deputy Assistant Secretary
DNFSB	Defense Nuclear Facilities Safety Board
DOE	United States Department of Energy
DOT	United States Department of Transportation
DSA	Documented Safety Analysis
ECP	Employee Concerns Program
EH	Department of Energy Office of Environment, Safety and Health
EH-3	Office of Corporate Performance Assessment
EH-31	Office of Quality Assurance Programs
EIS	Environmental Impact Statement
EM	Department of Energy Office of Environmental Management
EM-1	Office of the Assistant Secretary for Environmental Management
EM-2	Principal Deputy Assistant Secretary for EM
EM-3	Chief Operating Officer
EM-3.1	Office of Safeguards and Security and Emergency Management
EM-3.2	Office of Integrated Safety Management and Operations Oversight
EM-3.3	Consolidated Business Center
EM-3.4	Western Sites Project Office
EM-10	Office of Logistics and Waste Disposition Enhancements
EM-20	Office of Environmental Cleanup and Acceleration
EM-22	Office of Engineering
EM-24	Office of Licensing
EM-30	Office of Business Operations
EM-33	Office of Business Services
EM-40	Office of Performance Intelligence and Improvement
EM-43	Office of Performance Assessment
EPA	Environmental Protection Agency
ESE	Energy, Science and Environment
ES&H	Environmental, Safety, and Health
ESTARS	Electronic Suspense Tracking and Routing System
FAQS	Functional Area Qualification Standard
FEM	Field Element Manager
FRA	Functions, Responsibilities, and Authorities
FRAM	Functions, Responsibilities, and Authorities Manual
G	Guidance
HQ	Headquarters
HR	Office of Human Capital Management Chief Information Officer (IM)

DOE EM-HQ Quality Assurance Program Plan

IAEA	International Atomic Energy Agency
ICAO	International Civil Aviation Organization
ID	DOE Idaho Operations Office
IDP	Individual Development Plan
IG	Office of Inspector General
IM	Department of Energy Chief Information Officer
IMO	International Maritime Organization
IPABS	Integrated Planning, Accountability and Budgeting System
ISMS	Integrated Safety Management System
LSO	DOE Livermore Site Office
MA	Department of Energy Office of Management
NEPA	National Environmental Policy Act
NNSA	National Nuclear Security Administration
NRC	Nuclear Regulatory Commission
NSO	DOE Nevada Site Office
NTS	Non-Compliance Tracking System
O	Order
OA	Office of Independent Oversight and Performance Assurance
OCRWM	Office of Civilian Radioactive Waste Management
ODs	Office Directors (All EM-2 offices reporting directly to DASs and EM-3 HQ offices, except for EM-3.2, reporting to COO)
OECM	Office of Engineering and Construction Management
OH	DOE Ohio Field Office
OPI	Office of Primary Interest
OR	DOE Oak Ridge Office
ORP	DOE Office of River Protection
ORPS	Occurrence Reporting and Processing System
OSHA	Occupational Safety and Health Administration
P	Policy
PARS	Project Analysis and Reporting System
PD	Position Description
POC	Point of Contact
PPPO	DOE Portsmouth and Paducah Project Office
PSO	Program Secretarial Office(r)
QA	Quality Assurance
QAP	Quality Assurance Program
QAPP	Quality Assurance Program Plan
RF	DOE Rocky Flats Field Office
RL	DOE Richland Operations Office
SAR	Safety Analysis Report
SARP	Safety Analysis Report for Packaging
SEB	Source Evaluation Board
SELLS	Society for Effective Lessons Learned Sharing
SME	Subject Matter Expert
SNRs	Startup Notification Reports
SO	Secretarial Office(r)
SOPP	Standing Operating Policies and Procedures
SR	DOE Savannah River Operations Office
SSO	Source Selection Official
STD	Standard
STSM/A	Senior Technical Safety Manager/Advisor
TQP	Technical Qualification Program
TSR	Technical Safety Requirement
USQ	Unreviewed Safety Question

1. INTRODUCTION

1.1 Mission

The mission¹ of the Department of Energy's (DOE's) Office of Environmental Management (EM) is the accelerated risk reduction and cleanup of the environmental legacy of the Nation's nuclear weapons program and government-sponsored nuclear energy research. The program is one of the largest and most diverse and technically complex environmental cleanup programs in the world and includes responsibility for the cleanup of over 100 sites across the country. Included in that responsibility is the need to:

- Safely disposition large volumes of nuclear wastes;
- Safeguard materials that could be used in nuclear weapons; and,
- Deactivate and decommission several thousand contaminated facilities no longer needed to support the Department's mission and remediate extensive surface and groundwater contamination.

1.2 Policies and Management Principles

Quality Assurance (QA) and Integrated Safety Management (ISM) are expected to be inherent in all Environmental Management Headquarters (EM-HQ) activities. In conducting its mission, it is the policy of EM to ensure the safety and protection of workers, the public, and the environment while performing environmental management activities. EM strives to effectively plan, budget, execute, and evaluate its activities such that the right job is done correctly and safely the first time. It is also EM policy that quality requirements for products and services be clearly defined before work begins. Work processes are continuously monitored, assessed, and improved to achieve a rising standard of excellence in the quality and safety of EM programs, projects, products, and services. QA implementation is a line management responsibility, and as such, when any EM work is being performed, the principles of QA must be applied. In other words, whoever "owns" the work is responsible for the implementation of QA for that work.

1.3 Linkage Between Integrated Safety Management and Quality Assurance at EM-HQ

The Environmental Management Functions, Responsibilities, and Authorities (EM FRA) document contains the functions, responsibilities, and authorities necessary for achieving the ISM of EM activities. It is a central component of the EM response to DOE's commitment to promulgate requirements and associated instructions that provide direction and guidance for the safety management process, including responsibility for execution.

The EM FRA defines the safety management functions and responsibilities based on the requirements in DOE directives and Federal Regulations that are applicable to EM. The EM FRA captures all current environmental, safety, and health (ES&H) responsibilities assigned² to the DOE program or line offices by the corporate-level DOE FRAM (DOE Manual 411.1-1C, *Functions, Responsibilities and Authorities Manual*) and other applicable management and safety management directives. The EM FRA organizes responsibilities by means of the ISM System core functions³.

¹ Ref: <http://web.em.doe.gov/mission/mission2.html>

² "Assign" is used in the EM FRA to specify that the responsibility is Secretarial direction to a Secretarial Officer (SO) or Field Element Manager (FEM) via a DOE Directive. This is in contrast to a delegation of authority issued by a Cognizant Secretarial Officer (CSO) to an individual, through which a CSO directs the individual to carry out a particular function that is assigned to the CSO by the Secretary. For a delegation of authority the CSO remains responsible and accountable to the Secretary for the assignment.

³ Adapted to the FRA as: 1) Provide Direction, 2) Define Scope of Work, 3) Analyze Hazards, 4) Develop and Implement Controls, 5) Perform Work, 6) Collect Feedback and Pursue Improvement.

DOE EM-HQ Quality Assurance Program Plan

Each responsibility statement in the EM FRA identifies the EM-HQ organization with the implementing lead role or indicates that the authority is delegated to the Field Element Managers⁴ (FEMs) or to other individuals. The responsibility statements in the EM FRA include QA criteria per DOE O 414.1, *Quality Assurance*, thereby providing a link between ISM and EM-HQ QA, as well as to this document.

⁴ Field Element Manager indicates the Operations Office Manager, the Field Office Manager, or the Project Office Manager who takes direction from the Assistant Secretary for Environmental Management. Delegations have expiration dates.

2. EM-HQ QUALITY ASSURANCE (QA) IMPLEMENTATION OVERVIEW

This plan describes activities conducted by EM-HQ that relate to safety, risk, cost, and schedule in meeting DOE and EM objectives. EM-HQ management assures that:

- Senior management provides planning, organization, direction, control, and support to achieve DOE and EM objectives.
- ES&H risks and impacts are reduced while maximizing reliability and performance of EM work.
- The EM management system is consistent with principles and functions of DOE P 450.4, *Safety Management System Policy*, DOE P 226.1, *Department of Energy Oversight Policy*, and DOE O 226.1, *Implementation of DOE Oversight Policy*.
- EM improves its overall performance with both internal and external reviews, evaluations, and assessments (e.g., Office of Engineering and Construction Management (OECM); Office of Inspector General (IG); Government Accountability Office (GAO); Security and Safety Performance Assurance (SSA); and the Defense Nuclear Facilities Safety Board (DNFSB)) of its Field Offices and its contractors.

The key driver for QA is DOE O 414.1, *Quality Assurance*. (This document was written using revisions DOE O 414.1B and C.) QA for EM-HQ's functions applies to four categories of activities, which are:

1. Line Management and safety oversight of the Field (along with a limited set of nuclear safety-related activities) is EM's most central function in ensuring that QA programs and performance expectations are being appropriately described and administered within the EM program. EM employs a formal organizational structure coupled with leveraged relationships with the DOE Office of Environment, Safety and Health (EH) and the Office of Independent Oversight and Performance Assurance (OA) to ensure effective QA implementation within the EM program (see Section 4 of this document).
2. EM-HQ performs a very limited set of activities closely tied to nuclear safety-related activities, for which the requirements of NQA-1 or 10 CFR 830 apply. These activities are all as a reviewer and approver. Originating organizations responsible for execution of NQA-1 projects are mostly in the Field or contracted (see Section 5 of this document). The Office of the Assistant Secretary for Environmental Management (EM-1) is the primary interface with the Energy Science and Environment (ESE) Central Technical Authority (CTA) on matters of nuclear safety. Delegation of Authority for the nuclear safety requirements to the EM-HQ and Field Managers will be accomplished by using EM SOPP PS 5.15.
3. EM-HQ may, at times be involved in the use of safety software subject to DOE O 414.1C. These activities and associated requirements are delineated in Section 6.
4. A significant set of EM-HQ activities is programmatic and administrative in nature. These include program management, budget formulation, strategic planning, policy development, issuance of guidance, and others. This is in contrast to the Field execution of the EM mission which includes activities that have direct or immediate implications to safety; and activities such as facility operation, construction projects execution, excess facility deactivation and demolition, and waste sites remediation (see Section 7 of this document).

Implementation in accordance with these four categories is addressed in Sections 4, 5, 6, and 7, respectively. Because of the wide variation of EM-HQ activities, application of DOE O 414.1C is applied in a tailored manner (graded approach) appropriate to the direct effect of the activities' relationship to nuclear and conventional safety.

3. EM-HQ ORGANIZATION

EM-1 is ultimately responsible for leadership and the commitment to quality achievement and improvement for the EM mission. Figure 1 illustrates the organizational structure for EM-HQ. Details of the functions, authorities, and responsibilities of the various elements in the DOE EM organization are described in EM FRA Revision 3, dated March 31, 2004.

The EM FRA shows the direct lines of responsibility and authority from the Secretary of Energy to the Field Offices where the Field contractor oversight responsibilities reside. The approval of the EM FRA is the responsibility of the EM-1 while maintenance of the EM FRA is assigned to the Office of Integrated Safety Management and Operations Oversight (EM-3.2). EM-3.2 is responsible for ensuring that applicable safety requirements and the requirements of DOE O 414.1C and any subsequent updates to that Order are captured in the EM FRA.

The EM FRA identifies the organizational elements that have the responsibility and authority for managing, performing, and assessing work to meet the EM missions and objectives. In addition to delineating the responsibilities of EM-HQ organizations, the EM FRA documents delegations of authorities by EM-1 to the FEMs. The EM FRA also identifies internal and external interfaces, including other offices of DOE, as well as the Department of Transportation (DOT), Environmental Protection Agency (EPA), International Atomic Energy Agency (IAEA), International Maritime Organization (IMO), International Civil Aviation Organization (ICAO), and other agencies.

3.1 DOE-EM Interfaces

DOE-EM primary interfaces include:

- EM interfaces with SSA for effective implementation of safeguards and security policy requirements. The Office of Safeguards and Security and Emergency Management (EM-3.1) is the primary element to interface with SSA.
- DNFSB – The Chief Operating Officer (COO), EM-3, with the assistance of EM-3.2, and coordination through the Departmental Representative to the DNFSB (DR-1), is the primary interface for EM with the DNFSB, including providing information to the DNFSB, when needed, and providing input for response to DNFSB recommendations. EM-1, EM-3 and EM-3.2 present periodic briefings to the DNFSB on matters relating to nuclear safety and quality assurance at EM facilities. The interface with the DNFSB is conducted in accordance with DOE M 140.1-1B, *Interface with DNFSB*.
- EM-1 is the primary interface with ESE CTA on matters of nuclear safety. EM-3.2 is the primary interface with ESE CTA staff including the Chief of Nuclear Safety.
- EH - EM-3.2 has the primary interface with EH for assistance with assessments, lessons learned/operating experience, and QA-related support in overseeing EM sites.
- Other DOE Program Offices primary interfaces include:
 - Office of Civilian Radioactive Waste Management (RW) – Office of Logistics and Waste Disposition Enhancements (EM-10) and EM-3.2
 - National Nuclear Security Administration (NNSA); EM-3.2, EM-10, EM-24 and Western Sites Project Office (EM-3.4)
 - IG – Office of Business Operations (EM-30)
 - Office of Management (MA), Office of Human Capital Management (HR), Chief Financial Officer (CF), and Chief Information Officer (IM) – EM-30
 - OA – EM-3.2

3.2 National, Tribal and International Interfaces

Other examples of government interfaces that are carried out primarily by EM organizations are as follows:

- EM-24 – EPA, Nuclear Regulatory Commission (NRC), IAEA, DOT, IMO, ICAO
- EM-10, -20, -30 – States, Tribes, Advisory Boards, Non-Government Organizations
- EM-30 –GAO
- EM-10 – Packaging/transportation/disposal entities

Note: Some EM organizations that are not the primary interface may interact with external or other DOE organizations on an as needed basis. Their communications should be shared with the primary interface organization. In addition, EM organizations may interface with external organizations in their respective areas of responsibility, (e.g., EM-10; Packaging, Transportation, and Disposal; EM-24; Licensing; and EM-3.2, Safety).

The EM FRA provides additional information on these interfaces.

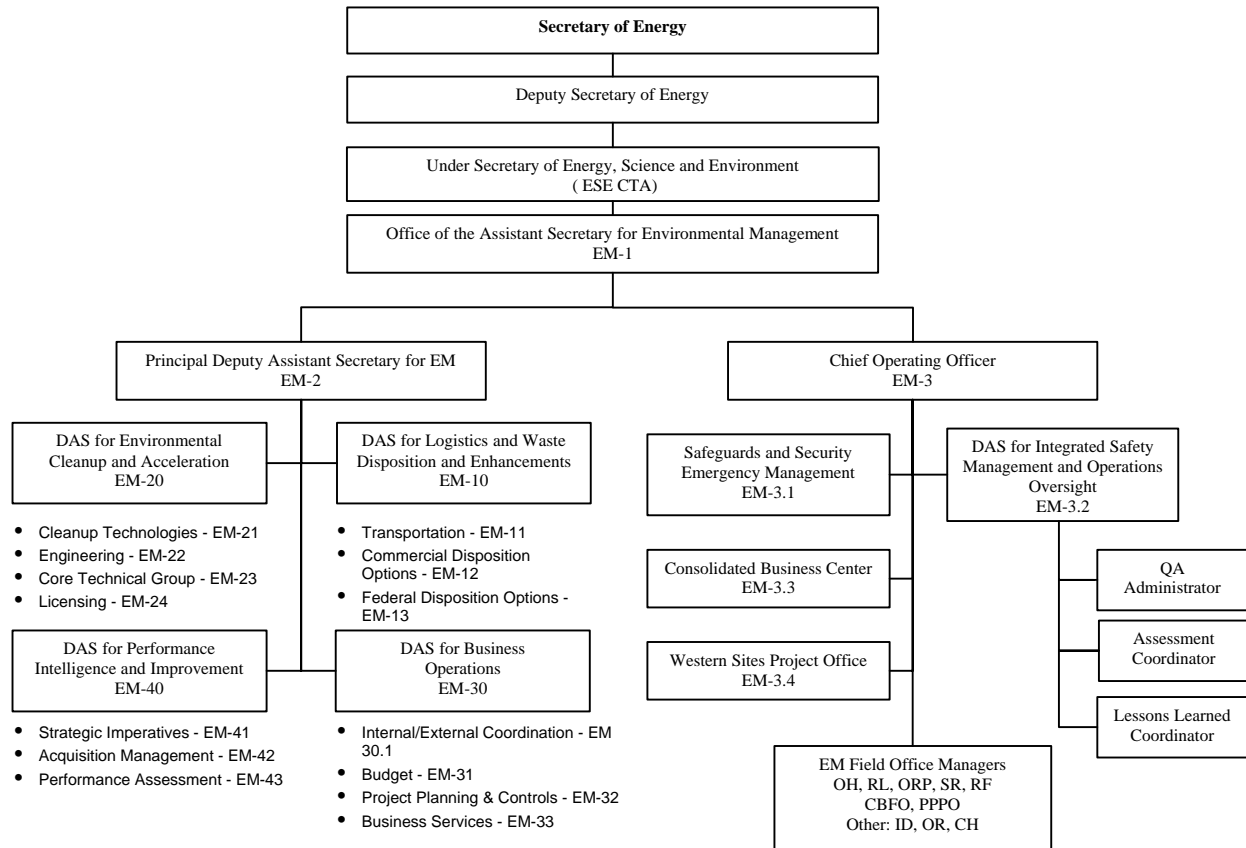
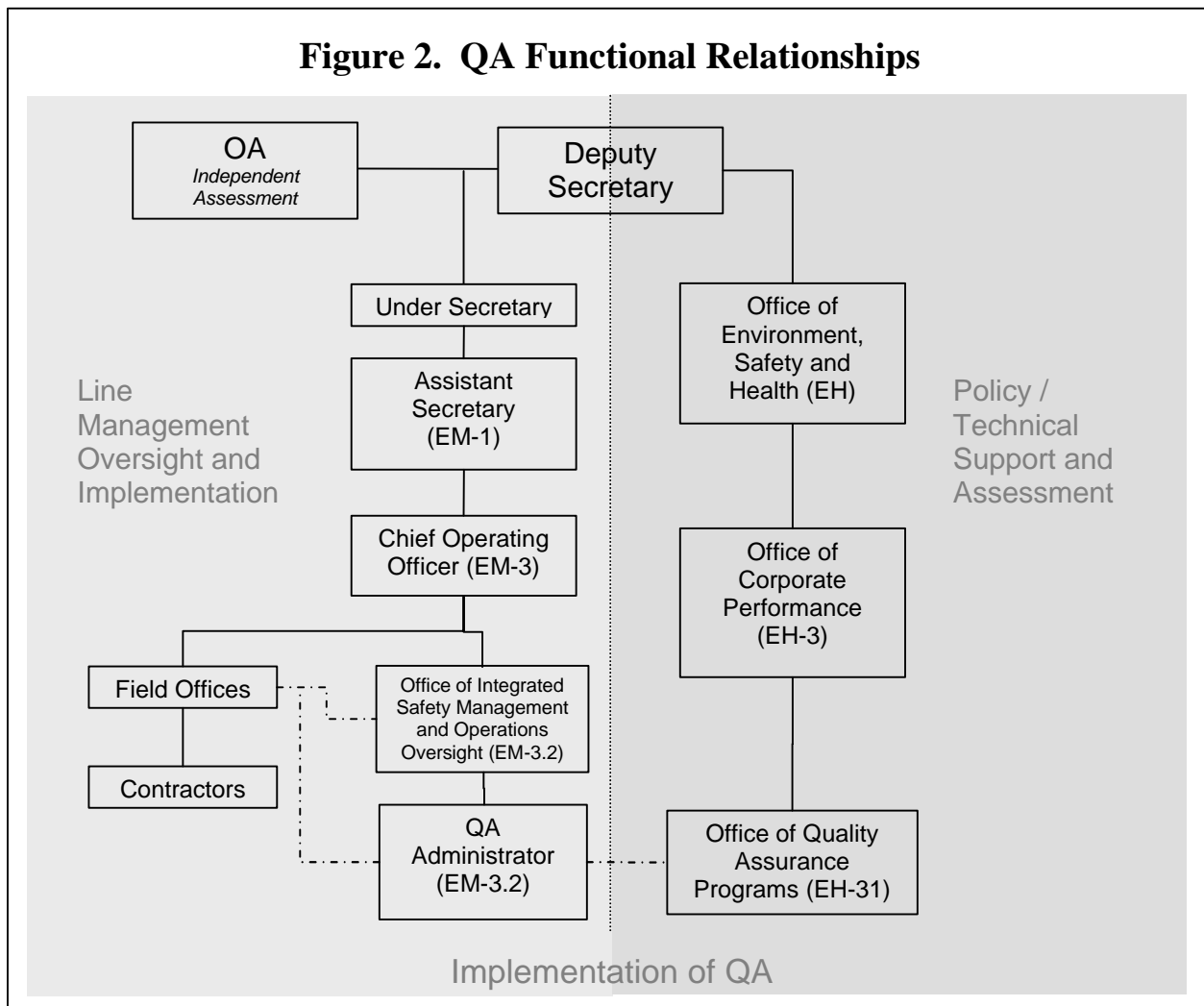

Figure 1 – EM Headquarters Organizational Chart

4. LINE MANAGEMENT OF EM QA

4.1 QA Flowdown

EM has responsibility for the execution of its Quality Assurance Program Plan (QAPP) as well as line responsibility for the execution of QA in its subordinate Federal and contractor organizations within the DOE EM Program. EM ensures that QA is appropriately implemented through the use of effective policy, oversight, technical support and assessments. It maintains a network of working relationships that ensure effective communication of QA expectations to the Field and its contractors as well as timely feedback of QA performance data from the Field. EM relies on EH's Office of Corporate Performance Assessment (EH-3) to assist in the interpretation and promulgation of policy and guidance as well as for technical support in its QA assessment program. OA provides for any independent assessments of EM QA programs at both the Field and Headquarters (HQ) (see Figure 2).



4.2 EM QA Administrator

The primary interface between EM Senior Management, the EH Office of Quality Assurance Programs (EH-31), which is within EH-3, and the Field, is the EM-HQ QA Administrator. The QA Administrator is responsible to the EM-3.2 Deputy Assistant Secretary (DAS) for the following:

- Preparing and administering the EM-HQ QAPP;
- Interacting regularly with the Field QA counterparts, EM-3.2 Site Liaisons, the Office of Performance Assessment (EM-43), and the EH Office of Quality Assurance on QA issues;
- Coordinating and participating in the review of EM Field Office QA Program (QAP) documents;
- Managing EM directed assessments, audits, or review of QA implementation in the Field;
- Annually assessing the implementation of the EM-HQ QAPP;
- Reviewing and approving EM-HQ NQA-1 or 10 CFR 830 project QA plans, procedures or instructions;
- Developing and administering the EM employee QA training program (both general and specialized); and
- Reviewing contractor QAPs where this authority is not delegated to the Field.

4.3 Field Interactions

The EM FEMs report to EM-3. The EM-3.2 DAS has the primary responsibility to ensure that the Field Offices and the contractors develop and implement their respective QAP documents to meet the requirements of DOE O 414.1C and all other applicable DOE Orders and Policies. Through the EM QA Administrator, the EM-3.2 DAS has the responsibility to review the Field Office QAP documents. EM-1 is responsible for approval of Field Office QAP documents. In addition, EM-3.2 also reviews, for EM-1 approval, the contractor QAPs not delegated to the Field.

EM-HQ's QA interactions with its Field Offices cover a broad range of activities. Some of these are very frequent and are a part of EM-3.2 oversight responsibility. Other types of interactions are less frequent and/or are case-by-case. These interactions are described below in the context of frequency and relation to the QA Order criteria.

Very Frequent Interactions

The following types of interaction occur daily or very often:

- **Criterion 3: Quality Improvement**—The EM QA Administrator and EM Lessons Learned Coordinator work with EH to evaluate daily occurrence notification and closed reports for QA implications. They address issues on an as needed basis. Weekly input is provided to EM by EH for the “EM Weekly Managers’ Call.” EH-3 will perform QA and safety trending and provide on a monthly basis to EM-3. The EM-3.2 safety data analysis team also provides trending information to EM-3.
- **Criterion 3: Quality Improvement**—EM-3.2 has individuals assigned as Site Liaisons. They interact daily with their assigned sites regarding ongoing activities, operations oversight, safety occurrences, Field needs from HQ, and HQ needs from the Field. They also visit sites for assessments and reviews. The EM Lessons Learned Coordinator collects Field operating and safety experience and lessons learned from across the DOE and shares it with the Field and with HQ through a variety of communication mechanisms (see Section 7.3).
- **Criterion 7: Procurement**—EM-HQ is closely involved with Field Offices for procurement of major capital projects. This is also the case for large deactivation and decommissioning (D&D) projects, site closure contracts, and Field site management contracts. Involvement can include approval of funding and participation in source evaluation boards. EM-HQ can

also utilize Field Offices as contracting mechanism for HQ-initiated projects and/or contracts for development, qualified services, transportation, waste disposal, and others.

- Criterion 10: Independent Assessment—EM-3.2, with RW, conducts joint audits of the EM site contractor QAP implementation to verify compliance with waste acceptance QA requirements imposed on Spent Nuclear Fuel and High Level Waste Projects. These joint assessments are conducted in accordance with RW procedures.

Oversight Interactions

EM-3.2 has specific responsibilities to conduct QA assessments of Field Offices to ensure that QA requirements are being satisfactorily implemented. In addition, QA may be included as a subset of other assessments conducted by EM-3.2 at the sites. These assessments are performed in accordance with EM SOPP PPC 7.2.

Related to this QAPP, oversight activities include:

- Criterion 1: Program—The EM Field Offices will each have their own Quality Assurance Program (QAP) documents consistent with the requirements of the governing DOE Orders and policies. All Field Office QAP documents are reviewed and approved by EM-HQ. The review of Field Office QAP documents is the responsibility of the EM-3.2 DAS and approval is done by EM-1. In most cases the review and approval of contractor QAP documents are currently delegated to the Field Office Elements under the purview of EM-3. This delegation is promulgated by memorandum from EM-1 to each FEM.
- Criterion 2: Training—EM-3.2 has the responsibility to verify that the training and qualification requirements for DOE Field personnel are in place and implemented. This is achieved via the EM-3.2 assessment activities.
- Criterion 3: Quality Improvement—EM-3 has the responsibility, as part of its Field Office oversight function, to ensure that EM Field Offices develop and implement effective quality improvement processes in their QA programs. In this effort, EM-3.2 participates in performance assessments and reviews of Field Office and contractor activities. This allows EM-HQ to implement effective cross-site lessons learned opportunities in identifying, analyzing, correcting, and preventing the recurrence of quality-related problems. In line with this, EM-3 conducts weekly Field Managers' calls to help identify quality and safety-related problems so that they can be addressed and provided to the Field as lessons learned. Participants from all EM-HQ organizations are also invited to participate in the call.
- Criterion 9: Management Assessments—Each EM Field Office conducts management self-assessments. EM-3.2 may be requested to participate in the Field Office management assessments as part of the Field oversight function. EM management may also request the participation, assistance, or support of Field Office personnel in the conduct of EM-HQ management assessments.
- Criterion 10: Independent Assessments—EM-HQ may schedule independent assessments of the Field Office Elements and conduct these assessments using EM-HQ personnel with support from OA and Office of Quality Assurance Programs (EH-31). These assessments will be based on an integrated assessments plan that addresses the requirements of DOE G 414.1-1A, *Management Assessment and Independent Guide* (or its successor), with special emphasis on emerging issues (an example is implementation of DOE STD 1186 2004, *Specific Administrative Controls*). Results of the independent assessments will be presented to the Field Offices and contractors. Corrective Action Plans (CAPs) will be developed, implemented as appropriate (in concert with governing Orders, policy, etc.). Corrective actions resulting from independent assessments performed by OA or resulting from Type A accident investigations are entered into the HQ Corrective Action Tracking System (CATS) of the Corrective Action Management Program

(CAMP) by the organization generating the CAP. The POC for the CAMP Team is a staff person within EM-3.2.

Less Frequent or Case-by-Case Interactions

- Criterion 3: Quality Improvement—Field Office Elements are required to submit their annual declarations on the implementation of ISM. These declarations are submitted to EM-3.2 for EM-HQ review and acceptance. EM-3, with assistance from EM-3.2 and the EM QA Administrator, issues guidance to the Field for expectations of the submittals. ISM System Descriptions for EM-HQ and EM Field Offices are required. EM-1 approves the EM-HQ ISM System Descriptions and the Field Office ISM System Descriptions.
- Criterion 4: Documents and Records—Each Field Office is responsible to manage its own records and documents. The Office of Business Services (EM-33), utilizing the Electronic Suspense Tracking and Routing System (ESTARS), controls memos and correspondence going to and from the Field or providing direction.
- Criterion 5: Work Processes—Many work processes conducted at EM-HQ, such as those listed in Appendix B, involve interaction with the Field. The degree of interaction for any specific work process depends on the specific issue, activity, facility, or project being addressed.
- Criterion 6: Design—Detailed design responsibilities are assigned to Field Offices, which is covered under the QAPs for the Field Office and/or their contractors. EM-HQ offices occasionally review designs (typically functional design specifications) from Headquarters' budget, safety, and mission perspective. The EM-43 OD and EM-3.2 DAS are currently developing the design threshold for EM-HQ review & approval to ensure the appropriate design is in place prior to Critical Decision 3 (CD-3) document development and approval by OEMC.
- Criterion 8: Inspection and Acceptance Testing—With one exception (see Section 7.8), inspection and acceptance testing responsibilities are assigned to Field Offices, which are covered under the QAPs for the Field Office and/or their contractors.
- Suspect/Counterfeit Items: Direct contractor oversight regarding S/CI requirements is the responsibility of the Field Offices. Field Office QAPs are required to address this requirement. EM-HQ is notified via the Occurrence Reporting and Processing System (ORPS) when cases arise.

4.4 Deficiency Resolution

Judgments of Need that arise out of Type A accident investigations or findings from OA assessments are recorded and tracked using the CAMP. The purpose of the CAMP is to implement a systematic process for developing, tracking, reporting, and implementing corrective actions to resolve the identified findings; and determine the effectiveness of the corrective actions in successfully resolving the findings and preventing their recurrence. The CAMP was initiated in response to the DOE Implementation Plan for DNFSB Recommendation 98-1, which expressed concern on the effectiveness of DOE to address and resolve safety issues identified by independent oversight. The database for CAMP is CATS. All other findings for EM-HQ assessments are documented and tracked by the EM-HQ organization performing the review/assessment. This is described in SOPP PPC 7.2. Reports generated are formalized and retained in each respective EM office's files. The EM-3.2 EM Lessons Learned Coordinator will interact with each organization to assist in developing lessons learned from the assessments, as appropriate, for the EM Complex.

In addition, EM-3.2 will perform oversight of the Field ORPS corrective action process, and Non-Compliance Tracking System (NTS) corrective actions.

5. NUCLEAR SAFETY REQUIREMENTS

5.1 NQA-1 and 10 CFR 830 Implementation at Headquarters

EM-HQ has overall responsibility to manage nuclear and nuclear related activities at its Field Offices, and supports a graded approach in the implementation of NQA-1 and 10 CFR 830 requirements. For the most part EM-HQ has a “corporate” management role for all of EM work and in general EM-HQ does not directly manage or supervise Field projects and activities. Rather, the projects/activities are almost always conducted by contractors, reporting to DOE Field Offices, with their own QA program (NQA-1). *In the rare circumstance that EM-HQ would directly manage a nuclear safety-related project or have direct involvement in nuclear safety-related activities, the HQ Project Manager will be responsible for creating a project-specific QA plan and project QA procedures in accordance with the requirements of NQA-1 or 10 CFR 830.*

In order for an HQ Project Manager to lead/manage a nuclear safety IDIQ contract, that Project Manager would be required to have the following qualifications:

- Training to meet qualification standards for the specific work to be performed;
- Knowledge of recordkeeping requirements; and
- Training and management support to establish and implement processes to detect and prevent quality problems (see Section 5.3).

The process for applying a graded approach at EM-HQ is described in this section and in Appendix B. EM-HQ does not have a QA organization. EM-HQ has a QA Administrator who is responsible for:

- Approving any EM-HQ individual NQA-1 or 10 CFR 830 Project QA Plans; and
- Conducting periodic audits of each individual EM-HQ NQA-1 and/or 10 CFR 830 project’s conduct of QA in comparison with what is stated in the project’s QA plan.

5.2 Nuclear Safety-Related Activities at EM-HQ (10 CFR 830 related)

Activities at EM-HQ that directly affect nuclear safety and licensing are conducted by the DAS for EM-3.2. The EM-3.2 DAS’s current delegated authorities are as follows and, except as noted, apply to activities at DOE Oak Ridge Office, DOE Portsmouth and Paducah Project Office, DOE Carlsbad Field Office, and Brookhaven National Laboratory:

1. *DOE O 425.1C:*

4.a.(3).(a).: Startup authority for a new hazard category 3 nuclear facility.

4.a.(3).(c). and (d).: Startup authority for the restart of a hazard category 2 nuclear facility following extended shutdown or extensive modification.

4.a.(4).(b).: Approve Startup Notification Reports (SNRs) if you are the startup authority; otherwise, make recommendation regarding approval.

2. *Title 10 CFR 830:*

Subpart B 830.204 (a). For hazard category 2 and 3 nuclear facilities: Approve the methodology, with EH concurrence, used to prepare the Documented Safety Analysis (DSA), including the criteria for classifying nuclear safety structures, systems, and components, and document the basis for approval whenever the contractor does not use a methodology for Table 2 of Appendix A to Subpart B of 10 CFR 830.

Subpart B 830.202 (b) (3) and App A F.3. Approve final hazard categorization for hazard category 2 and 3 nuclear facilities.

Subpart B 830.203 (b) and (c). For hazard category 2 and 3 nuclear facilities approve Unreviewed Safety Question (USQ) procedures and processes of the contractor.

Subpart B 830.203 (e). Approve changes determined to involve a USQ prior to implementation, and approve continued operations when a USQ is determined to exist.

Subpart B 830.206 (b) (1) and (2). For hazard category 2 and 3 nuclear facilities, approve the preliminary DSAs, including nuclear safety criteria where required.

Subpart B 830.207 (b) and (d). For hazard category 2 and 3 nuclear facilities, approve the DSAs and revisions thereto.

Subpart B 830.205 (a) (2). Approve Technical Safety Requirements (TSRs), and revisions thereto, and other hazard controls for hazard category 2 and 3 (and below) nuclear facilities.

Subpart B 830.202 (a) and (b) and Subpart B Appendix A, Section E.2. For hazard category 2 and 3 (and below) nuclear facilities, establish and approve the safety and authorization basis in accordance with 10 CFR Part 830.

Subpart B 830.207 (b) and (d), Appendix A, Section I.1. Issue a Safety Evaluation Report that documents the basis upon which the approvals have been made.

3. *DOE M 411.1-1C, Table 6.: For hazard category 2 (and below) facilities, review and approve the authorization agreement.*
4. *DEAR Clause 970.5204-2.: Approve the contract ES&H requirements (except for DOE Portsmouth and Paducah Project Office (PPPO)).*

As an aside, EM-3.2 performs an oversight role in the Field development and approval of SNRs. This oversight is a QA check to ensure proper implementation of delegated authority for SNRs. Assessments are performed to validate the processes used.

5.3 NQA-1 Implementation at Headquarters

The EM-20 DAS is delegated the authority to approve or deny exemption requests from requirements in DOE O 460.1B *Packaging and Transportation Safety* as well as other Program Secretarial Office (PSO) authorities within the Order dealing with approval of certain packaging, etc. Appropriate training, management systems, and other QA procedures for this authority are to be maintained in accordance with NQA-1.

5.4 Project QA Plans, Procedures or Instructions

The activities listed above that affect nuclear safety require a separate project QA Plan (See Table 1 for Criteria for Project QA Plans). The plan may be organized to address either a scope of activities within the organization or a specific project. If the EM-HQ Project QA Plan is written to address NQA-1 requirements, management and independent assessments must also be addressed and performed for that project. Other EM-HQ activities that may need a Project QA Plan, QA Procedure or QA Instruction will be decided on a case-by-case basis. Criteria for this would include the necessity for more rigor or

DOE EM-HQ Quality Assurance Program Plan

specificity than the EM-HQ QAPP requires. For example, an Environmental Impact Statement (EIS) under the National Environmental Policy Act (NEPA) requires implementation of QA requirements, and in some cases, a separate QA Plan may be required. These QA Plans would be done following the NEPA protocols and be consistent with the EM-HQ QAPP. The EM QA Administrator will assist activity and project managers in determining if other EM-HQ activities/projects are in need of additional QA documentation (i.e., plan, procedure or instruction). QA procedures or instructions will address necessary QA requirements that would enhance the implementation of the activity/project, but do not need the rigor of a project QA Plan. Examples of activities that may use QA procedures or instructions include development of Individual Development Plans (IDPs), performance of management assessments, lessons learned dissemination processes, and records of change control. Procedures are formally controlled. Instructions are for one time use, could be in the form of a memorandum, and are to clearly indicate the expectation.

Each Project QA plan should contain the following as a minimum:

- Description of the project or scope of activities;
- Identification of aspects that affect nuclear safety;
- Which of the ten criteria for 10 CFR 830.120 or 18 criteria from NQA-1 specifically apply to the project or activities;
- A description of how the selected requirements from 10 CFR 830.120 or NQA-1 are applied; Identification of other EM or DOE organizations, if any, that participate in QA activities (for example, EM-3.2 for auditing); and
- Any additional requirements contained in the DOE QA Order (DOE O 414.1C).

DOE EM-HQ Quality Assurance Program Plan

Table 1 - Criteria for Project QA Plans

NQA-1 Criteria	
1. Organization	10. Inspection
2. Quality Assurance Program	11. Test Control
3. Design Control	12. Control of Measuring and Test Equipment
4. Procurement Document Control	13. Handling, Storage, and Shipping
5. Instructions, Procedures, and Drawings	14. Inspection, Test, and Operating Status
6. Document Control	15. Control of Nonconforming Items
7. Control of Purchased Items and Services	16. Corrective Actions
8. Identification and Control of Items	17. Quality Assurance Records
9. Control of Special Processes	18. Audits
10 CFR 830.120 Criteria	
1. Management / Program	6. Performance /Design
2. Management / Personnel Training and Qualification	7. Performance / Procurement
3. Management / Quality Improvement	8. Performance / Inspection and Acceptance Testing
4. Management / Documents and Records	9. Assessment / Management Assessment
5. Performance / Work Processes	10. Assessment / Independent Assessment

6. SOFTWARE QUALITY ASSURANCE AT EM-HQ

6.1 EM-HQ Software subject to NQA-1 or 10 CFR 830

Criteria for applicability of DOE O 414.1C *Quality Assurance*, and ultimately NQA-1 or 10 CFR 830, to safety software used by EM-HQ includes safety software directly or indirectly related to nuclear safety or nuclear operations.

At this time there is no software used at EM-HQ for which use, development, or maintenance is subject to the requirements of DOE O 414.1C.

6.2 Implementation of Software Quality Assurance at EM-HQ

Potential application of software QA requirements to EM-HQ software falls into three categories, which are:

- Providing Subject Matter Expert (SME) assistance to the Field – such activities are conducted in accordance with the relevant Field organization’s QA implementation for that software (including the qualifications of the SME).
- Utilizing software subject to the requirements of DOE O 414.1C for nuclear safety-related applications – If EM-HQ did utilize software subject to DOE O 414.1C, the users would need to develop written plans similar to that for a project QA plan. The scope of such plans would be limited to: a) Application of Verification and Validation (V&V) standard for procurement of the software; b) qualifications and training of users; c) maintaining a record of the V&V performed at HQ to assure its proper application; and d) specification of the circumstances to which the software may be applied. Note that QA decisions applied to the input and to the results of the use of such software in a program, project, or activity are separate from that of the software itself.
- Software development – If EM-HQ initiates development of software for which formal QA is applicable, requirements of DOE O 414.1C will be specified to the developer. When the product is delivered, the developer provides a certification that the requirements have been met. When this certification is provided, QA at EM-HQ is the same as for users above.

EM-HQ has one qualified Software QA (SQA) representative (within EM-24). The EM-HQ SQA representative works with the EM-3.2 Assessment Coordinator to ensure necessary/upcoming SQA Field assessments are included on the EM-HQ Assessment Schedule. Most SQA assessments done in the Field are a result of the Field Office’s request. As part of the 2002-1 IP commitments, each EM Field Office has at least one qualified SQA representative.

7. MANAGEMENT AND ADMINISTRATIVE QUALITY ASSURANCE

As described in the overview, a significant part of EM activities are managerial and administrative, examples of which are program management, budget formulation, strategic planning, policy development, issuance of guidance, and others. With regard to EM management and administration, Table 3 indicates typical activities, responsibilities, and interactions as they relate to the ten criteria in DOE O 414.1C and associated ISM principles and core functions.

7.1 Criterion 1: Program

The EM-HQ QA implementation results from an integrated comprehensive program comprised of management systems established to assign responsibilities and authorities, define policies and requirements, and provide for the performance and assessment of work or operations. Compliance with and implementation of the management systems and processes identified in this document contribute to fulfilling the EM mission. These systems and processes provide for achievement of quality and enhancement of safe operations in a planned and systematic manner. EM-1 has overall responsibility and accountability for the EM QA Program. The implementation of the key management systems to accomplish the EM QA Program is carried out by various organizations within EM-HQ as described within this document. These organizations may develop additional written documents, contracts, policies, plans, procedures, and instructions to implement functions that are directly applicable to their scope of work.

7.2 Criterion 2: Personnel Training and Qualification

All EM personnel shall receive general QA training centered around the EM-HQ QAPP scope and applicability. This general QA training will be one hour in length. Additional specific QA training (approximately 4 hours in length) for certain positions, including EM managers, will also be provided. (see details later in this section) Personnel assigned to perform functions associated with EM-HQ management systems shall have education, experience, and/or training commensurate with the functions associated with the work. DOE mandated policies provide for the inclusion of qualification requirements in position descriptions, which provides a means for initial qualifications. Selection officials perform and document an evaluation of the candidate's qualifications against the requirements. DOE M 426.1-1A, *The Federal Technical Capability Manual* is used as the basis for determining the qualification requirements of specific safety and quality-related technical positions.

EM-HQ personnel assigned to perform the functions important to the EM mission and objectives receive training as appropriate. Training and qualification of EM-HQ QA administrator is performed in accordance with the DOE Technical Qualification Program (TQP). EM-1 is responsible for selecting the EM positions who are required to become Senior Technical Safety Manager/Advisor (STSM/A) qualified. The managers who have been placed in designated STSM/A positions are trained and qualified in accordance with the STSM functional area qualification standard (FAQS). Each EM Manager (COO/DAS/OD) is responsible to determine if any TQP training is required for their staff and to ensure that the requirements are met. If TQP training is to be required of an employee already performing in the job that is deemed to require the additional technical training, the Manager must give that employee ample time to meet the qualifications, as well as time during work hours to complete the necessary preparatory work and training. These determinations shall be recorded in the employee's Position Description (PD), in their respective Performance Elements, if needed, and in their IDPs, as appropriate. Other necessary or proposed training is also to be captured in the employee's IDPs.

Training is provided to EM-HQ personnel to ensure that personnel maintain their proficiency for performing their assigned duties and responsibilities and to meet the qualification requirements of their

DOE EM-HQ Quality Assurance Program Plan

functions and positions. The respective COO/DAS/ODs, in coordination with EM-33, are responsible for determining and documenting these qualifications and training requirements.

DOE EM-HQ Quality Assurance Program Plan

Table 2 – Quality Assurance at EM-HQ for other than NQA-1 or 10 CFR 830 Related Activities

DOE O 414.1 Criteria	Typical DOE/EM-HQ Activities	EM Lead Organization	Examples of Management Tools	ISMS Link ⁵	Interaction with Field Offices
1. Program	<ul style="list-style-type: none"> Develop and maintain the EM FRA Develop and maintain EM-HQ QAPP 	EM-3.2	<ul style="list-style-type: none"> FRA Mission & Functions Statement 	<ul style="list-style-type: none"> Principles 1, 2, and 4 	Review & Approve Field Office QAPs
2. Personnel Training and Qualification	<ul style="list-style-type: none"> ISM & EM-HQ QAPP Training 	EM-3.2	<ul style="list-style-type: none"> SOPP: PS 5.15 SOPP: PS 5.2 	<ul style="list-style-type: none"> Principle 3 	Oversight and Assessment
	<ul style="list-style-type: none"> Position Qualifications 	EM-30	<ul style="list-style-type: none"> SOPP: PS 5.3 		
	<ul style="list-style-type: none"> Formal Training Program Informal Training 	All COO/DAS/ODs	<ul style="list-style-type: none"> FTCP SOPP: PPC 7.2 		
3. Quality Improvement	<ul style="list-style-type: none"> Conduct Assessments Lessons Learned & Feedback Improve Processes & Procedures 	EM-3.2	<ul style="list-style-type: none"> ECP CAPs & CAMP SOPP: PPC 7.2 	<ul style="list-style-type: none"> Core Function 5 	Participate in Assessments
4. Documents & Records	<ul style="list-style-type: none"> Control records as required by regulation and policy, e.g. FRA, SOPP and NQA-1 project plans 	EM-30	<ul style="list-style-type: none"> SOPP: AS 6.12 DOCS EMCTS ESTARS 	<ul style="list-style-type: none"> Principles 1, 2, 3, 4, 5, 6, and 7. 	Independent Records Management
5. Work Processes	<ul style="list-style-type: none"> All except NQA-1 activities 	All	<ul style="list-style-type: none"> See Appendix A for a list of management tools. SOPP: PPC 7.2 	<ul style="list-style-type: none"> Principles 5 and 6. Core Function 4. 	Review and Approval; Oversight and Assessment
6. Design	<ul style="list-style-type: none"> Conduct assessments and oversight of Field activities 	EM-3.2 EM-43	<ul style="list-style-type: none"> Assessment Plans and Field QAPs SOPP: PPC 7.2 	<ul style="list-style-type: none"> Core Functions 1 & 5 Principles 4 & 7 	Oversight and Assessment

⁵ ISM Guiding Principles: 1) Line Management Responsibilities for Safety, 2) Clear Roles and Responsibilities, 3) Competence Commensurate with Responsibilities; 4) Balanced Priorities; 5) Identification of Safety Standards and Requirements; 6) Hazard Controls Tailored to Work Being Performed; 7) Operations Authorization

ISM Core Functions: 1) Define the Scope of Work; 2) Analyze Hazards; 3) Develop and Implement Hazard Controls; 4) Perform Work within Controls, 5) Provide Feedback and Continuous Improvement

DOE EM-HQ Quality Assurance Program Plan

DOE O 414.1 Criteria	Typical DOE/EM-HQ Activities	EM Lead Organization	Examples of Management Tools	ISMS Link⁵	Interaction with Field Offices
7. Procurement	<ul style="list-style-type: none"> Assure safety and quality requirements are incorporated in contracts Development/Review of contracts 	SEB Chair and SSO; EM-42 for process ; EM-30	<ul style="list-style-type: none"> SOPP: ACQ 2.3 SOPP: ACQ 2.5 SOPP: ACQ 2.7 SOPP: ACQ 2.10 SOPP: EM-7 ACQ 2.9 	<ul style="list-style-type: none"> Principles 3, 5, and 7. Core Function 1. 	Major capital projects, site closure contracts, site management contracts
8. Inspections & Acceptance Testing	<ul style="list-style-type: none"> Conduct assessments and oversight of Field activities 	EM-3.2 EM-43	<ul style="list-style-type: none"> Assessment Plans and Field QAPs SOPP: PPC 7.2 	<ul style="list-style-type: none"> Principles 1 & 2 	Oversight and Assessment
9. Management Assessment	<ul style="list-style-type: none"> Conduct internal and Field assessments 	EM-3.2 EM-43	<ul style="list-style-type: none"> DOE G 414.1-1A SOPP: PPC 7.2 	<ul style="list-style-type: none"> Principles 1, 2, 3, and 4. Core Function 5. 	Participate in Assessments
10. Independent Assessment	Conducted by OA on EM and Field	EM-3.2	<ul style="list-style-type: none"> DOE G 414.1-1A 	<ul style="list-style-type: none"> Principles 1, 2, 3, and 4. Core Function 5. 	Assist in preparations for OA Audit

Note: SOPPs PS 5.15 and PPC 7.2 are currently draft procedures.

5 ISM Guiding Principles: 1) Line Management Responsibilities for Safety, 2) Clear Roles and Responsibilities, 3) Competence Commensurate with Responsibilities; 4) Balanced Priorities; 5) Identification of Safety Standards and Requirements; 6) Hazard Controls Tailored to Work Being Performed; 7) Operations Authorization

ISM Core Functions: 1) Define the Scope of Work; 2) Analyze Hazards; 3) Develop and Implement Hazard Controls; 4) Perform Work within Controls, 5) Provide Feedback and Continuous Improvement

Training Responsibilities

Each responsible COO/DAS/OD ensures that the training and qualification requirements for subordinate personnel are current and consistent with the requirements of applicable manuals, procedures, and guidance. Each COO/DAS/OD will ensure on an ongoing basis that employees have satisfied and continue to satisfy these requirements. Specific responsibilities include:

- EM-33 maintains training and qualification records of EM-HQ employees.
- EM-33 administers processes, training requirements, management of training programs, and training approval.
- In consultation with the FTCP Agent for EM, EM-33 updates the TQP position list to identify the Federal positions whose duties and responsibilities require them to meet the FAQs for safety software/STSMs. EM-33 is responsible for updating employee PDs with this requirement.
- Specific SME training/education remains the responsibility of the COO/DAS/OD to maintain capabilities of the organization.
- Documentation certifying completion of all training shall be provided by COO/DAS/OD to EM-33 for inclusion in employees' official training records.

Specialized QA Training for EM Managers and Selected Technical Positions

Successful implementation of integrated QA and ISM in EM-HQ will require clear understanding of this QA Program Plan. The 4-hour training session will address:

- ISM;
- Management Expectations;
- Roles, Responsibilities (in the FRA) and Interfaces;
- The EM-HQ QAPP Requirements and Implementation;
 - QA Records and recordkeeping;
 - Procedures and Guidelines; and
 - Quality and safety improvement approaches, methods, and the feedback processes including self-assessment/management assessment and corrective action training.

All EM management positions (including ODs) are required to take this training. EM Senior Management (EM-1, Principal Deputy Assistant Secretary for Environmental Management (EM-2), EM-3, DASs) will decide which positions are the "selected technical positions" and ensure documentation in those persons' PDs and IDPs. The QA Administrator will provide criteria to EM management to assist in the selection of those additional positions requiring this training. The Senior Management has 2 months from the issuance of the EM-HQ QAPP to provide an initial list of selected personnel to the QA Administrator.

EM-3.2 has the responsibility to develop and implement this specialized EM-HQ QA training within one year after the EM-HQ QAPP is issued.

Qualifications and training that are associated with safety-related activities and software described in Sections 5 and 6 are controlled in accordance with the QA plans that apply to the specific projects and activities.

General Training for Implementation of EM-HQ QAPP

The EM QA Administrator has the responsibility for ensuring that a general employee training program for QA is developed and implemented within 6 months after the EM-HQ QAPP is issued. The general employee training consists of a one hour session for each EM employee to be introduced to the EM-HQ

DOE EM-HQ Quality Assurance Program Plan

QAPP and be educated in the contents of the DOE QA Order and the applicability of this plan to the employee.

7.3 Criterion 3: Quality Improvement

Continuous improvement of the quality of work products, processes, procedures, and personnel qualification is the cornerstone of EM-HQ management activities to accomplish the objectives of the EM mission. EM management encourages and empowers employees and contractors to identify quality related problems and report them to management so that they are assessed and corrected appropriately.

In general, quality-related problems may be identified by both internal and external sources during performance of oversight and assessments. EM employees and management identify quality-related problems through various mechanisms including management and independent assessments, employee concerns program, performance assessments, and others. Furthermore, EM management conducts weekly calls where participants are encouraged and expected to identify and report problems that affect quality; and has monthly status calls with each Field site to address issues and projects. Lessons can be drawn and applied to prevent recurrence and, when applicable, used to improve processes, procedures, and personnel qualification. The QA Administrator ensures that EM-HQ quality-related problems are recorded and tracked to ensure that the issues are addressed appropriately. The EM Lessons Learned Coordinator ensures that any noteworthy operational and safety experience and lessons learned (both positive and negative) are made available to the personnel in HQ and in the Field. The following table highlights the EM Lessons Learned Coordinator's activities for capturing and disseminating operational experience including lessons learned.

What	Lessons Learned in Safety, QA, Best Management Practice with complex-wide implications
Frequency	Immediate Safety Quality Impacts (Regularly [real-time]) Summary Reports, trends, best practices (monthly basis)
To whom	EM Management and to Field Managers/Contractors via appropriate channels
Mechanisms	Memoranda, E-mails, Conference Calls, Website (including SELLS and EM Lessons Learned Site), workshops, seminars, conference. Weekly Calls
Information Sources	Assessments/Reviews (Internal [i.e., EM-HQ, Field] and Independent [OA], and External [e.g., IG, DNFSB, EPA]); ORPS, NTS and CAIRS Data Trade Journals Conferences/Workshops Corrective Action Management Program (CAMP)/Corrective Action Tracking System (CATS)

The EM Lessons Learned Coordinator interfaces with the Office of Engineering (EM-22) for environmental compliance lessons learned, EM-43 for project performance lessons learned, and EM-24 for NEPA lessons learned.

At times lessons learned collected by the EM Lessons Learned Coordinator can present unique opportunities for significant procedural improvements in the Field. In this event, the EM Lessons Learned Coordinator will work with the appropriate EM personnel to evaluate the potential for procedural improvements. These personnel recommend improvements to EM-3.2 DAS who upon evaluation will forward the recommendation to EM-3. EM-3 will address the recommendation to the Field Office Manager who, along with the Management and Operations (M&O) contractor, will evaluate it for both

effectiveness and contractual impacts. The Field Office will report back to EM-3 any significant improvement in safety or quality performance. The Lessons-Learned coordinator will document the results and provide them to the appropriate EM personnel. See Figure 3.

Figure 3. Procedure Improvement Process From Lessons Learned

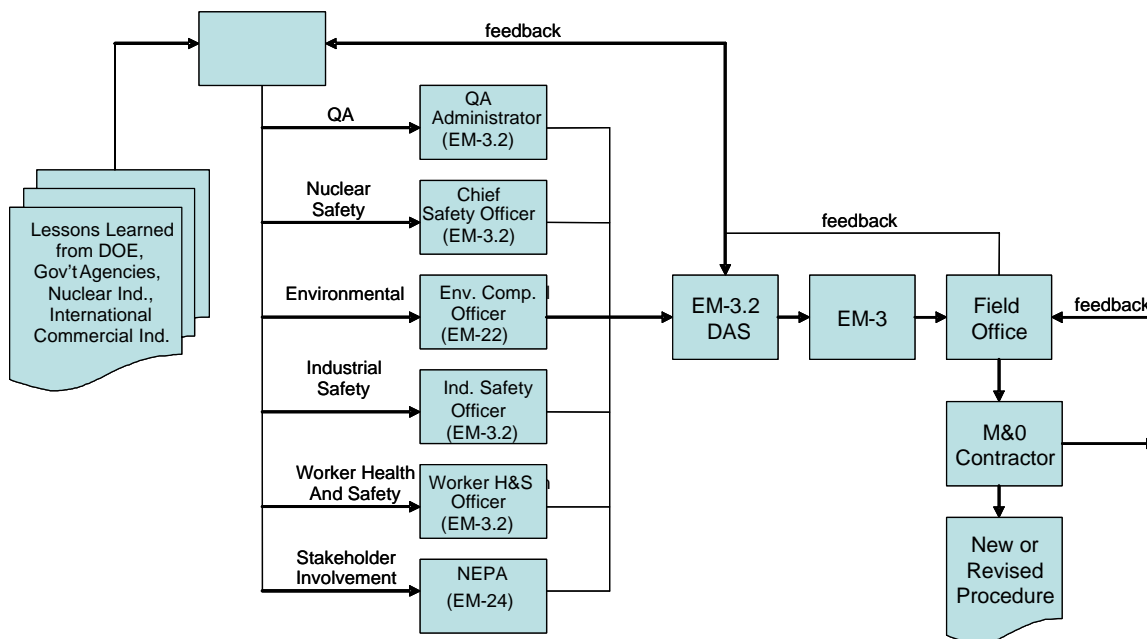

The EM quality improvement process consists of:

- Identifying Quality Problems;
- Analyzing Causes;
- Developing CAPs, tracking actions, and using CAMP for tracking Type A/OA findings;
- Taking immediate steps to prevent recurrence;
- Deriving lessons learned and providing feedback; and
- Tracking identified problems and corrective actions to ensure appropriate closure.

All identified problems, results of the causal analysis, suggested steps to prevent recurrence, and status of CAPs as well as site QA issues uncovered by HQ personnel through HQ/Field or HQ/self-assessments, should be communicated to the EM-QA Administrator and to the management of the affected organization (see Sections 7.9 and 7.10).

7.4 Criterion 4: Documents and Records

A large number of official records and documents created by most EM-HQ organizations are managed within DOE Administrative Records Schedule, which provides a customized listing of records contained in the National Archives and Records Administration General Records Schedule as customized to the needs of DOE and its contractors. This guidance is available at the following website: <http://cio.doe.gov/RBManagement/Records/adminrns.htm>. However, in the context of QA, a very small

number of HQ documents have ongoing revisions once issued (in contrast with design, construction, operation and D&D of facilities). Typical revision controlled records by the responsible EM Project Manager include the EM FRA, standard operating procedures, and administrative procedures.

Responsible EM project managers for NQA-1 and 10 CFR 830.120 projects control documents for safety-related activities described in Sections 5 and 6 in accordance with the QA plans for the specific projects and activities.

7.5 Criterion 5: Work Processes

EM-HQ work processes cover a broad range and types of activities. They can be categorized in the functional groups as:

1. Provide Field oversight and monitoring;
2. Review and approve/certify;
3. Conduct assessments;
4. Assist Field organizations in reviews and appraisals;
5. Provide program advocacy, technical assistance, and technical direction;
6. Provide policy and program direction;
7. Participate in DOE HQ response to Field emergencies and upset situations; and
8. Provide business support services (including human resource management, administrative activities, budget, procurement and public affairs).

Generally, the drivers for these EM-HQ functions are DOE Policies, Orders, Manuals, and Technical Standards. Occasionally, outside oversight groups such as the DNFSB will provide recommendations to DOE that are integrated into EM-HQ functions through Department generated implementation plans and other procedures. A variety of management tools that support these processes are listed in Appendix A.

In addition, there could be singular situations that arise requiring development and implementation of new work processes. For this reason, it is essential that flexibility be maintained for addressing such instances. As such, there is a potential for one-of-a-kind and first-of-a-kind work processes to be created and carried out.

Specialized Work Process Functions related to Environmental Management:

Configuration Control Board (CCB): The CCB is a management system designed to achieve the following two objectives: (1) to properly define, coordinate, evaluate and disposition all proposed changes to the program elements under HQ configuration control; and (2) to effectively plan, execute and control fiscal year financial resources provided to EM Field and HQ organizations. EM-32 is responsible for the management of the CCB process.

National Environmental Policy Act (NEPA): Compliance with the National Environmental Policy Act (NEPA) is required for all major Federal actions with the potential for significant effects on the quality of the environment. All EM activities with such potential, such as major construction or renovation, waste cleanup, decommissioning, and policy implementation, must comply with NEPA and DOE Order 451.1B which details the Department's NEPA program and includes the NEPA responsibilities of each Secretarial Officer and NEPA Compliance Officer (NCO). EM-24 coordinates NEPA activities for EM including assistance in the preparation and review of documents, advice on NEPA, and support in processing NEPA actions.

Resource Conservation and Recovery Act (RCRA), Comprehensive Environmental Response, Compensation, and Liability Act (CERCLA): At beginning of fiscal year, EM-20 prepares a list of

pending cleanup decisions utilizing information in IPABs and distribute to the Field for verification and necessary modifications.

Remedy Review Team Chair evaluates list of pending decisions and identifies candidates for review based on: 1) potential for national consistency/precedent setting concerns, e.g., establishing soil cleanup level for radionuclides; 2) costs anticipated to exceed \$30 million; 3) application of controversial approach, e.g., monitored natural attenuation; and 4) Use of an Applicable or Relevant and Appropriate Requirements (ARAR) waiver, e.g., technical impracticability. *(For the proposed actions that the Remedy Review Chair does not believe an internal remedy review is warranted, the Remedy Review Chair will prepare summary assessment of the basis for recommending approval by the Board of the proposed action.)*

Based on timing of expected decisions, and the type of site problems being addressed, Remedy Review Team Chair develops tentative review schedule with site personnel for each review candidate and begins to identify appropriate individuals to serve as reviewers. [NOTE: Review teams typically consist of three to four individuals with relevant expertise and experience - Review Team Chair, HQ personnel or Field project manager(s), and in limited situations, a national lab representative or private consultant].

Site project managers submit supporting information (e.g., Proposed Plan, RI/FS, CMS, etc.) as requested and make it available to the review team at least two full weeks in advance of the scheduled review meeting.

As part of the review (typically a two-hour conference call or meeting), the Field Project Manager and their support team will give a brief overview of the project, i.e., problem being addressed, remedial options considered, basis for preference, etc. Review team comments and recommendations are shared orally with site representatives during the meeting and subsequently provided in writing to the Regulatory Review Board with a cc: copy to the Assistant Secretary and the respective Site Manager.

Waste Determinations: EM-24 has the responsibility for supporting EM-1 in providing the Secretary of Energy with information, analyses and recommendations relating to waste determinations that certain wastes resulting from reprocessing of spent nuclear fuel is not high-level waste. Such determinations are made under the framework of the following: 1) National Defense Authorization Act for Fiscal Year 2005, Section 3116, 2) Sections I.2.F.18 and II.B of DOE Order 435.1, and 3) the NRC Final Policy Statement, Decommissioning Criteria for the West Valley Demonstration Project at the West Valley Site.

Low Level Waste Disposal Facility Federal Review Group (LFRG): Under the Atomic Energy Act, DOE Self Regulates the disposal of its Low Level Waste (LLW). The DOE Regulatory Disposal process is defined in DOE Order 435.1. As tasked by the Order, The Office of Environmental Management is the DOE Regulator for LLW. The LFRG was chartered in 1999 by EM to conduct the regulatory oversight process and maintain the administrative record of the regulatory licensing, performance monitoring, maintenance and closure of LLW facilities. The LFRG Program Management Plan, approved by the Department's Field Management Council in October 2000, established the LFRG Roles and Responsibilities for both HQ and Field organizational team representatives and provides the framework and guidelines for the conduct of the LLW Regulatory Oversight Process. This oversight process can include, when applicable, regulatory integration with requirements of external regulatory agencies (ex. NRC, EPA). EM-20 is the responsible organization for the LFRG.

End States: The EM Program has adopted the concept of an end state vision for site cleanup. DOE issued a policy on the use of end states on July 15, 2003. The policy is intended to improve the effectiveness of the environmental cleanup program by focusing on cleanup goals that are clear, technically defensible, and achievable. The cleanup goals are based on a vision for the site at the end of the cleanup effort (the 'end state') which is driven by the expected future land use at the site. The Department's policy requires individual sites that are undergoing cleanup to develop an end state vision in cooperation with regulators, and in consultation with stakeholders. Sites continue to refine and complete their End States Vision documents with input from their regulators and stakeholders. The Office of Core Technical Group (EM-23) is the responsible organization overseeing this activity.

7.6 Criterion 6: Design

With few exceptions (such as special nuclear safety-related investigations mandated by EM-1 and reviews resulting from Type A investigations), EM-HQ does not perform original design work. The type of activities at EM-HQ that may require design-related skills is limited to review and approval. EM-HQ may review designs from Headquarters' budget, mission, and safety perspective. The EM-43 OD and EM-3.2 DAS are currently developing the design threshold for EM-HQ review and approval to ensure the appropriate design is in place prior to Critical Decision 3 (CD-3) document development and approval by OEMC. Detailed design responsibilities are assigned to Field Offices, which is covered under the QAPs for the Field Offices and/or their contractors.

On occasion, EM-HQ may employ resources to conduct independent design reviews of Field projects, facilities, or equipment. EM-HQ performs assessments concerning design of EM facilities or equipment per EM SOPP PPC 7.2.

7.7 Criterion 7: Procurement

EM-HQ procurement is typically conducted for special support services and major contracts. QA requirements are imposed on a contractor via the contract. It is the issuing organization's responsibility (specifically the Contracting Officer, with input from SMEs) to ensure proper QA and safety requirements are included in the Request for Proposal and ensuing contract. Key procurement activities include:

- Evaluating contract performance and DOE contract management and recommending necessary strategic redirections;
- Developing and maintaining procedures and ensuring that appropriate planning is factored in the source selection process (actions performed by EM Contract Management Advisory Council);
- Developing procurement and acquisition strategies for the EM complex and unique sites or projects; and
- Identifying trends in contracting practices across the complex that are impacting EM effectiveness.

7.8 Criterion 8: Inspection and Acceptance Testing

With one exception, inspection and acceptance testing responsibilities are assigned to Field Offices, which are covered under the QAPs for the Field Office and/or their contractors. The exception is that EM-20 tests and evaluates industrial and DOT Specification waste packaging. QA for this activity is per EM-20's project-specific QA Plan as addressed in Section 5.

EM-HQ performs oversight assessments of Field inspection and testing processes and procedures as necessary in accordance with EM SOPP: PPC 7.2.

7.9 Criterion 9: Management Assessments

Headquarters Management Self-Assessments

EM performs management self-assessments as appropriate to determine policy, program, procedural and managerial effectiveness, to obtain internal and external feedback, and to make overall improvements in key management systems. The frequency and the need for self-assessment is determined by each EM Manager (OD and above). The EM QA Administrator may recommend to the affected organization that a self-assessment be performed. As part of the specialized QA training, EM managers will be educated in the performance of self-assessments.

EM 3.2 DAS and EM-20 DAS are responsible for ensuring that a self-assessment of their EM-HQ safety oversight function be performed biennially in accordance with the DNFSB 2004-1 DOE Implementation Plan dated June 2005.

EM-HQ management conducts self-assessment to measure the effectiveness of selected management systems and processes. These self-assessments provide a basis for improving management systems, clarifying functions, responsibilities and authorities, and establishing priorities for work process improvements.

Each COO/DAS/OD organization conducts self-assessments, as appropriate, of the key management systems, processes, and procedures. Management self-assessments cannot be delegated. These assessments are conducted with the direct participation of the responsible COO/DAS/OD, who may solicit training assistance or guidance from the EM QA Administrator. Each COO/DAS/OD's organization will maintain records/reports of self-assessments in accordance with DOE Administrative Records Schedule 16. Copies of each completed EM management self-assessment report are to be provided to the EM QA Administrator who will maintain the control file of all self-assessments for EM-HQ.

Self-assessment results are used as management feedback for internal lessons learned, and CAPs are developed to implement any necessary improvements to the management systems, processes, and procedures. These corrective actions can be incorporated in training to enhance staff understanding of missions and functions of their organization, knowledge of the work processes, and proper use of the procedures.

The review of reports generated from the EM Employee Concerns Program (managed by EM-33) is a component of the management assessment.

Responsible EM project managers, for projects governed by NQA-1 described in Sections 5 and 6, must perform management self-assessments in accordance with the QA plans for the specific projects and activities.

EM Field Assessments

EM-HQ conducts safety and project oversight assessments of the Field Office Elements. These assessments are based on the requirements of DOE P 450.4, *Safety Management Policy* and DOE P 226.1, *Department of Energy Oversight Policy*, and DOE O 226.1, *Implementation of DOE Oversight Policy* with special emphasis on emerging issues as needed. These are performed in accordance with SOPP: PPC 7.2 (see Section 4.3).

In addition, EM-HQ may participate in Field Office assessments of contractors, and occasionally, as requested, self-assessments of the FEM.

7.10 Criterion 10: Independent Assessments

Independent assessments are an important activity that EM-HQ supports to ensure successful mission performance. Results of the independent assessments are critical components for EM's continuous quality improvement efforts. To ensure independence, EM-HQ uses the support of OA to conduct independent assessments of EM-HQ activities. These assessments are conducted in accordance with DOE O 470.2B, *Independent Oversight and Performance Assurance Program*.

It is expected that OA provides the qualified individuals to lead and conduct the assessments. Independent SME and technically qualified individuals may be provided by EM-HQ from sources that are not connected to the organization being assessed. The EM QA Administrator and Assessment Coordinator should work closely with OA on the detailed plans of the assessment to ensure that appropriate team is configured and the objectives of the assessment are accomplished within the defined scope.

Assessment results are documented and reported by the assessment team to the responsible management for review. Follow-up actions including corrective actions are developed by the assessed organization. All CAPs resulting from the independent assessments are approved and issued by EM-1. Upon approval, corrective actions are entered into CAMP (i.e., CATS) by the organization responsible for implementing the action.

Projects governed by NQA-1, described in Sections 5 and 6, are subject to independent assessments.

DOE EM-HQ Quality Assurance Program Plan

APPENDIX A – EM MANAGEMENT TOOLS

The key management tools used by EM-HQ are listed in Table 3. “Management Tools” denotes structured programs, systems, recurring activities, and methods (e.g., databases, reporting protocols, etc.) that EM-HQ management uses to assure performance and quality of services. These tools support efficient and effective management of EM’s programs and systems and meeting the intent and requirements of the Government Performance and Results Act (GPRA).

Table 3 – EM-HQ Management Tools

Name	Description/Reference	Primary Responsible Organization for EM
Configuration Control Board (CCB)	CCB is a management system designed to achieve the following two objectives: (1) to properly define, coordinate, evaluate and disposition all proposed changes to the program elements under HQ configuration control; and (2) to effectively plan, execute and control fiscal year financial resources provided to EM Field and HQ organizations.	EM-32
Contract Management Advisory Council (CMAC)	CMAC has been established to EM on contracting issues and to serve as an interactive channel to address contracting services in support of the EM program. The council addresses: (1) contracting strategies for HQ and Field management contracts; (2) recommendations on extend/compete decisions for Field management and EM-HQ contracts; (3) review of performance-based incentives; (4) review of contractor fee earnings; and (5) special studies as directed by EM-1 or determined to be necessary by the CMAC.	EM-32
Closure Planning Guidance	The purpose of this document is to turn initiatives from the Top to Bottom Review into formal processes that can predictably deliver results and safely complete cleanup of the EM Program by 2035. See DOE, <i>EM Closure Planning Guidance</i> , June 1, 2004.	EM-43
Communications Portal	This Portal provides a one-stop location for EM employees to access information supporting the program's goal of accelerated risk reduction and cleanup completion. The Portal is also an online resource for EM business operations and employee/HR information. The information on the Portal currently includes a set of community pages and is sorted by the following categories: <i>Programmatic, Human Capital, Administrative, EM in the News, Phone Directory and Systems/Databases</i> .	EM-33
Computerized Accidents and Incidents Reporting System (CAIRS)	CAIRS is used to collect and analyze DOE and DOE contractor reports of injuries, illnesses, and other accidents that occur during DOE operations. More information can be found at http://www.eh.doe.gov/cairs/ .	EM-3.2
Corrective Action Management Program (CAMP)	CAMP implements a systematic process for developing, tracking, reporting and implementing corrective actions to resolve the identified findings; and determines the effectiveness of the corrective actions in successfully resolving the findings and preventing their recurrence. These actions successfully complete the generalized process for the Feedback and Continuous Improvement core safety function within the Integrated Safety Management System. For more information on CAMP, go to http://www.eh.doe.gov/camp .	EH-31

DOE EM-HQ Quality Assurance Program Plan

Name	Description/Reference	Primary Responsible Organization for EM
Electronic Suspense Tracking and Routing System (ESTARS)	ESTARS offers an online solution to track commitments real-time through a single desktop tool. ESTARS is a web-based application that captures the complete lifecycle of a task – cradle to grave. It will capture all coordination and correspondence as a matter of permanent record. For more information on ESTARS go to: www.estars.lockheedmartin.com .	EM-33
EM Safety Management Functions, Responsibilities, and Authorities Document (EM FRA)	EM FRA contains ES&H functions, responsibilities, and authorities necessary for achieving the integrated safety management of EM activities. It is a central component of EM's response to the DOE's commitment to promulgate requirements and associated instructions that provide direction, guidance, and define responsibilities for the safety management process. The EM FRA defines the safety management functions and responsibilities predicated on the requirements in DOE directives and the DOE FRAM that are applicable to EM.	EM-3.2
EM Weekly Calls	These calls are led by EM-2 and EM-3 and involve EM Field Managers, other PSO sites with EM work, and HQ staff. The calls are to encourage dialogue and communication of accomplishments, needs, issues and lessons learned.	EM-3.2
End States	The EM Program has adopted the concept of an end state vision for site cleanup. DOE issued a policy on the use of end states on July 15, 2003. The policy is intended to improve the effectiveness of the environmental cleanup program by focusing on cleanup goals that are clear, technically defensible, and achievable. The cleanup goals are based on a vision for the site at the end of the cleanup effort (the 'end state') which is driven by the expected future land use at the site. The Department's policy requires individual sites that are undergoing cleanup to develop an end state vision in cooperation with regulators, and in consultation with stakeholders. Sites continue to refine and complete their End States Vision documents with input from their regulators and stakeholders. For more information and complete End States Vision documents, go to www.em.doe.gov .	EM-23
Federal Technical Capability Panel	The Federal Technical Capability Program provides for recruitment, deployment, development, and retention of Federal personnel with the demonstrated technical capability to safely accomplish the Department's missions and responsibilities. The program consists of four elements, of which one is a Federal Technical Capability Panel consisting of Senior Technical Safety Managers to oversee the implementation of the program. Reference: DOE P 426.1, <i>Federal Technical Capability Policy for Defense Nuclear Facilities</i> or www.ftcp.org .	EM-1/FTCP Agent designee
Gold Chart Metrics	EM measures performance and accountability using EM's Corporate Performance Measures (Gold Chart). Gold Chart measures are critical indicators of EM's progress towards meeting the program's goals. Because Gold Chart data are under strict configuration control, the data are locked in the current configuration for all years. Any changes to Gold Chart quantities must be requested and approved by the EM Configuration Control Board. Reference: DOE, EM, <i>FY 2006 Spring Budget Formulation Module</i> , March 12, 2004.	EM-32

DOE EM-HQ Quality Assurance Program Plan

Name	Description/Reference	Primary Responsible Organization for EM
Integrated Planning, Accountability, and Budgeting System (IPABS)	IPABS is a project-based management system that supports the EM Program. IPABS supports the EM Vision to complete cleanup at most sites by 2006 by providing stable business processes focused on supporting site closure and cleanup completion. IPABS consists of two major components: 1) The IPABS Handbook describes the top-level EM business processes and associated responsibilities necessary to fulfill the EM vision; and 2) The IPABS-Information System (IPABS-IS), along with the EM Corporate Database, provides the information and reports that support the IPABS Handbook and other EM information requirements. Additional information on the IPABS can be found at http://web.em.doe.gov/ipabs .	EM-32
Non Compliance Tracking System (NTS)	NTS is a database for DOE contractors to report unsafe actions or conditions that possibly violate nuclear safety requirements for protecting workers and the public. The contractor line management tracks to closure the corrective actions in each report to prevent recurrence. The corrective actions are approved by both DOE Field office personnel and investigators in the Office of Price-Anderson Enforcement. For more information on NTS see http://www.eh.doe.gov/reporting_dbs.html .	EM-3.2
Occurrence Reporting and Processing System (ORPS)	ORPS provides timely notification to the DOE complex of events that could adversely affect: public or DOE worker health and safety, the environment, national security, DOE's safeguards and security interests, functioning of DOE facilities, or the Department's reputation. For more information see http://www.eh.doe.gov/paa/orps.html .	EM-3.2
Project Analysis and Reporting System (PARS)	PARS delivers project status and assessment information to DOE senior managers and key program stakeholders. PARS is part of DOE's project reform initiative that was launched in June 1999. A key requirement for this initiative is a directive that the Office of Management, Budget and Evaluation (OMBE) establish a project management tracking and control system. PARS is specifically designed to fulfill this requirement. Reference, DOE, Office of Management, Budget and Evaluation (OMBE) and OECM <i>Project Assessment and Reporting System (PARS) User Manual, Version 3.03, September 2004</i> .	EM-43
Project Baseline Summary (PBS)	PBS is a management tool that summarizes information about each project. PBS is used for planning, budgeting, executing, and evaluating. Baseline information in PBS is consistent with the project baseline at the point of time when PBS is developed. Reference: DOE, EM, <i>Integrated Planning, Accountability, and Budgeting System Handbook</i> , February 16, 1999.	Budget – EM-31 Contracts – EM-43 Project – EM-32, EM-2

DOE EM-HQ Quality Assurance Program Plan

Name	Description/Reference	Primary Responsible Organization for EM
EM Standing Operating Policies and Procedures (SOPP)	<ul style="list-style-type: none"> • SOPP: PS 5.15 - Process for Delegation of Safety Authorities (Draft, no date) • SOPP: PS 5.2 - Technical Capability Program (4/24/02) • SOPP: PS 5.3 - Senior Technical Safety Manager (4/24/02) • SOPP: PPC 7.2 - EM-HQ Oversight Assessment Program (Draft, no date) • SOPP: AS 6.12 - Controlled Correspondence (5/10/02) • SOPP: ACQ 2.3 - Performance Based Contracting (4/24/02) • SOPP: ACQ 2.5 - Contract Planning, Management and Administration (6/26/02) • SOPP: ACQ 2.7 - Procurement Integrity (3/6/02) • SOPP: ACQ 2.10 - Contractor Performance Evaluations (3/19/02) • SOPP: EM-7 ACQ 2.9 - Transfer of Contracts and Financial Assistance Instruments (1/15/02) 	EM-33
Technical Expertise Matrix	This is a matrix of EM employees who have self-identified expertise in certain functional areas. The Matrix is used to assist in requests from sites for assistance and to staff HQ review/assessment activities.	EM-3.2
Weekly Reports/ 30-60-90 Day Reports	These are reports of significant HQ and Field activities. Input is received from HQ and Field staff.	EM-3/EM-2
Safety Information Management System (SIMS)	SIMS is a DNFSB-issues tracking system maintained by the Office of the Departmental Representative to the DNFSB (DR).	EM-3.2
Safety Basis Information System	This system lists nuclear facilities, location and type (i.e., category 1, 2, 3) for all DOE including EM. It is maintained by EH.	EM-3.2

APPENDIX B – GRADED APPROACH

B.1 Graded Approach Requirement

DOE O 414.1 Section 4.a. (1) states:

Each DOE organization must develop and implement a QAP that addresses QA criteria as defined in paragraph 4b using a graded approach and describing how the criteria and graded approach are applied.

B.2 Factors in Applying the Graded Approach

Citing DOE G 414.1-2, Section 4.1.3, the grading process should be used to evaluate hazards or risks and to determine the appropriate controls to address those hazards or risks. This process is accomplished by deliberate quality planning and is based on facility-specific or activity-specific factors, such as:

- The relative importance to safety, safeguards, and security;
- The magnitude of any hazard or risk involved;
- The life-cycle stage of a facility;
- Impact/consequences on programmatic mission of a facility;
- The particular characteristics of a facility or activity;
- The nuclear safety classification, hazard category or performance classification of the item or activity;
- Adequacy of existing safety documentation;
- Complexity of products or services involved; and
- History of problems at a site or facility.

B.3 Applying the Graded Approach at EM-HQ

Much of EM-HQ work does not directly affect nuclear safety. In the unlikely circumstances that EM-HQ takes primary and direct responsibility for management, operation, storage, transport, or disposal of nuclear materials for its programs, projects, or facilities, the graded approach will require rigorous application of NQA-1.

The method by which EM-HQ decides on applying NQA-1 is based on guidance in DOE G 414.1-2. That is, the grading process for a specific Field project undertaken by EM-HQ will use four steps, which are to:

1. Verify whether the consequences and probability of a failure warrant application of NQA-1 to the project. The criteria for this determination are:
 - If a formal safety analysis is required for the facility or project based on the requirements 10 CFR 830 part B; or
 - If EM-HQ activities can affect the probability, consequences, and mitigating controls of/for accidents (effectively a USQ Screening type of determination).
2. Identify the specific QA requirements to be applied.
3. Determine the depth, extent, and degree of rigor necessary in the application of QA requirements.
4. Communicate and implement the selected requirements and degree of rigor by means of documented procedures and controls.

The logic, method of implementation, and basis for grading will then be documented in a project-specific QA plan. Creating the QA plan for a nuclear safety-related project is based on the type of project and its characteristics (such as whether the project involves fabrication, procurement, software, etc.).

DOE EM-HQ Quality Assurance Program Plan

If EM-HQ decides to directly manage a nuclear safety-related project, and organization and procedures have *not* been established for this purpose, the basic steps to establish a project-specific QA plan include:

- Select which of the 18 NQA-1 Criteria apply to the project;
- For each of the criteria that apply, decide how it will be implemented for the project;
- Based on criteria application, create, review, and approve project-specific QA procedures;
and
- Assign a QA SME as a project QA representative.

For an extended project, the grading should be periodically reviewed in light of changes that may have occurred, and if appropriate, the plan revised to accommodate those changes.