

John T. Conway, Chairman
A.J. Eggenberger, Vice Chairman
John E. Mansfield
R. Bruce Matthews

DEFENSE NUCLEAR FACILITIES SAFETY BOARD

625 Indiana Avenue, NW, Suite 700, Washington, D.C. 20004-2901
(202) 694-7000



December 1, 2003

The Honorable Spencer Abraham
Secretary of Energy
1000 Independence Avenue, SW
Washington, DC 20585-1000

Dear Secretary Abraham:

The Defense Nuclear Facilities Safety Board (Board) was directed by Congress to conduct a study of the adequacy of the K-Area Materials Storage (KAMS) facility and related support facilities such as Building 235-F at the Savannah River Site, Aiken, South Carolina, for the storage of defense plutonium and defense plutonium materials. This report was mandated by Congress in Section 3183 of the Defense Authorization Act for Fiscal Year 2003, Public Law 107-314. Section 3183 directed that this study be provided both to Congress and to the Secretary of Energy. Our report on this matter is enclosed for your consideration.

The Board concludes that plutonium can be stored safely in the KAMS facility as currently configured for a limited period of time. For extended storage, the Board believes that certain safety enhancements described in the enclosed report should be provided. The Board further concludes that the Department of Energy should expedite decisions on disposal of excess plutonium, and should re-evaluate its plutonium storage plan to determine if there are better options (such as a new plutonium storage facility) for extended storage of plutonium materials at the Savannah River Site.

The Board appreciates the support provided by the Savannah River Site to members of our staff as they conducted on-site reviews as part of this study.

Respectfully submitted,

A handwritten signature in black ink, appearing to read "John T. Conway".

John T. Conway
Chairman

Enclosure

**PLUTONIUM STORAGE
AT THE
DEPARTMENT OF ENERGY'S
SAVANNAH RIVER SITE**

REPORT TO CONGRESS

**DEFENSE NUCLEAR FACILITIES
SAFETY BOARD**



DECEMBER 2003

John T. Conway, Chairman
A.J. Eggenberger, Vice Chairman
John E. Mansfield
R. Bruce Matthews

DEFENSE NUCLEAR FACILITIES SAFETY BOARD

625 Indiana Avenue, NW, Suite 700, Washington, D.C. 20004-2901
(202) 694-7000



December 1, 2003

To the Congress of the United States:

The Defense Nuclear Facilities Safety Board (Board) is pleased to submit to Congress its report on plutonium storage at the Savannah River Site in Aiken, South Carolina. This report was mandated by Congress in Section 3183 of the Defense Authorization Act for Fiscal Year 2003, Public Law 107-314. Section 3183 directed that the Board conduct a study of the adequacy of the K-Area Materials Storage facility (KAMS) and related support facilities such as Building 235-F at the Savannah River Site, Aiken, South Carolina, for the storage of defense plutonium and defense plutonium materials. As required by Section 3183, the Board has also provided the enclosed report to the Secretary of Energy.

The Board concludes that plutonium can be stored safely in the KAMS facility as currently configured for a limited period of time. For extended storage, the Board believes that certain safety enhancements described in the enclosed report should be provided. The Board further concludes that the Department of Energy should expedite decisions on disposal of excess plutonium, and should re-evaluate its plutonium storage plan to determine if there are better options (such as a new plutonium storage facility) for extended storage of plutonium materials at the Savannah River Site.

Respectfully submitted,

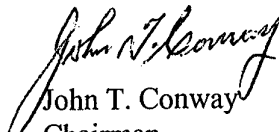
John T. Conway
Chairman

A. J. Eggenberger
Vice Chairman

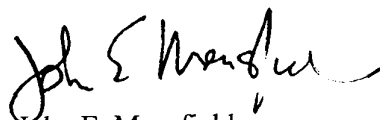
John E. Mansfield
Member

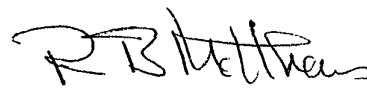
R. Bruce Matthews
Member

Enclosure

PREFACE

DEFENSE AUTHORIZATION ACT OF FISCAL YEAR 2003 PUBLIC LAW 107-314

SEC. 3183. STUDY OF FACILITIES FOR STORAGE OF PLUTONIUM AND PLUTONIUM MATERIALS AT SAVANNAH RIVER SITE.

(a) **STUDY.**—The Defense Nuclear Facilities Safety Board shall conduct a study of the adequacy of the K-Area Materials Storage facility (KAMS), and related support facilities such as Building 235–F, at the Savannah River Site, Aiken, South Carolina, for the storage of defense plutonium and defense plutonium materials in connection with the disposition program provided in section 3182 and in connection with the amended Record of Decision of the Department of Energy for fissile materials disposition.

(b) **REPORT.**—Not later than one year after the date of the enactment of this Act, the Defense Nuclear Facilities Safety Board shall submit to Congress and the Secretary of Energy a report on the study conducted under subsection (a).

(c) **REPORT ELEMENTS.**—The report under subsection (b) shall—

(1) address—

(A) the suitability of KAMS and related support facilities for monitoring and observing any defense plutonium or defense plutonium materials stored in KAMS;

(B) the adequacy of the provisions made by the Department for remote monitoring of such defense plutonium and defense plutonium materials by way of sensors and for handling of retrieval of such defense plutonium and defense plutonium materials; and

(C) the adequacy of KAMS should such defense plutonium and defense plutonium materials continue to be stored at KAMS after 2019; and

(2) include such proposals as the Defense Nuclear Facilities Safety Board considers appropriate to enhance the safety, reliability, and functionality of KAMS.

(d) **REPORTS ON ACTIONS ON PROPOSALS.**—Not later than 6 months after the date on which the report under subsection (b) is submitted to Congress, and every year thereafter, the Secretary and the Board shall each submit to Congress a report on the actions taken by the Secretary in response to the proposals, if any, included in the report.

EXECUTIVE SUMMARY

CONCLUSIONS AND PROPOSALS

Department of Energy's Plutonium Disposition Program. During the past decade, the Department of Energy (DOE) has significantly changed its plans for how to stabilize and store excess plutonium. Originally, DOE proposed and designed a state-of-the-art facility (called the Actinide Packaging and Storage Facility [APSF]) to safely store and monitor all excess plutonium for an indefinite time period. Also planned was a proposed plutonium immobilization facility to provide a near-term disposition pathway for excess plutonium not designated for mixed-oxide (MOX) fuel.

Instead of proceeding with these specially-designed, modern facilities for stabilization, packaging, and storage of plutonium, DOE now proposes to rely on a combination of 50-year old facilities that currently do not meet modern safety standards. The lack of careful, consistent planning has forced the site chosen for plutonium storage, Savannah River Site (SRS), to focus on what can be done with existing facilities, foreclosing options that may have been both cost-effective and safety-conscious.

K-Area Materials Storage. Storage of plutonium in the K-Area Materials Storage (KAMS) facility can be accomplished safely for a limited period of time (roughly 4 to 5 years) provided existing safety controls are maintained. For storage beyond this period of time, improvements such as fire protection upgrades should be undertaken. *For extended storage (beyond 4 to 5 years), the Defense Nuclear Facilities Safety Board (Board) proposes that DOE install fire protection systems and eliminate unnecessary combustibles in the KAMS facility.*

Building 235-F. DOE should carry out its plan to remove plutonium materials from Building 235-F (235-F). DOE should not plan extended storage of plutonium in 235-F until it has studied the proposals in this report. *These proposals are (1) establish an acceptable safety basis for storage of plutonium, (2) conduct a systematic evaluation of the safety systems to determine needed upgrades, (3) perform a structural analysis assessing seismic adequacy of the facility measured by current acceptance criteria, and (4) decontaminate unused process cells.*

Remote Monitoring and Retrieval of Material. Neither the KAMS facility nor 235-F are equipped to provide remote monitoring of the physical condition of stored material. DOE's plan for handling, moving, and shipping a damaged, potentially contaminated container from KAMS for further disposition has not been defined and validated. *Thus, the Board proposes that DOE develop and implement validated procedures for the handling and intrasite shipment of plutonium containers, including damaged containers.*

FB-Line. The FB-Line can complete its stabilization and packaging mission safely. Readiness reviews for startup of the new plutonium stabilization furnaces and the packaging system have been completed.

Building 772-F and the Savannah River Technology Center. These facilities have adequate analytical capabilities to support the plutonium storage mission at the SRS. These capabilities will need to be maintained throughout the storage mission.

Adequacy of Facilities Beyond 2019. Once the existing SRS facilities have been made adequate and can be expected to safely perform storage and processing missions, safe use of the facilities beyond 2019 requires management of facility aging. SRS has established a program for managing facility aging that consists of conducting preventive, predictive, and corrective maintenance. The program for predicting problems with safety equipment before failure is particularly noteworthy. SRS can be expected to maintain needed safety systems related to plutonium storage and handling. The cost of maintaining safety equipment in these facilities will likely increase with time, and will probably become prohibitive.

Programmatic Risks. DOE's current plutonium disposition plan incurs significant programmatic risk. The immobilization facility has been cancelled, and the planned MOX Fuel Fabrication Facility has not yet obtained regulatory approval. DOE has no apparent plan for the disposition of approximately 5 metric tons of excess plutonium not designated for processing in the MOX facility. *For these reasons, the Board proposes that DOE (1) expedite the development of a complete, well-considered plan for the disposition of all excess plutonium to preclude unnecessary extended storage of plutonium at SRS, and (2) conduct a new study of available options for the storage of plutonium at SRS.*

Long-Term Management and Storage of Plutonium. During the last decade, a state-of-the-art plutonium storage facility (the APSF) was designed by DOE. This facility contained systems assuring safe storage of plutonium for long periods of time and was designed to current safety standards and expectations. Such a modern plutonium storage facility would satisfy the above proposals and would provide safety, reliability, and functionality of the storage mission.

TABLE OF CONTENTS

Section	Page
1 INTRODUCTION	1-1
1.1 Congressional Mandate to the Defense Nuclear Facilities Safety Board.....	1-1
1.2 Background.....	1-1
1.3 Scope of Study.....	1-2
1.4 Study Assumptions	1-6
1.5 Study Approach	1-6
2 CONCLUSIONS AND PROPOSALS	2-1
2.1 Plutonium Disposition Program.....	2-1
2.2 Suitability of Facilities	2-2
2.3 Remote Monitoring and Retrieval of Material	2-5
2.4 Adequacy of Facilities Beyond 2019	2-6
APPENDIX A STUDY FINDINGS	A-1
APPENDIX B TEXT OF ORIGINAL REPORTS BY THE BOARD'S STAFF	B-1
APPENDIX C TYPICAL STORAGE CONTAINERS	C-1
APPENDIX D PUBLIC LAW 107-314, SECTIONS 3181, 3182, and 3183	D-1
GLOSSARY OF ACRONYMS	GL-1
REFERENCES	R-1

1. INTRODUCTION

1.1 CONGRESSIONAL MANDATE TO THE DEFENSE NUCLEAR FACILITIES SAFETY BOARD

In Section 3183 of Public Law 107-314¹, Congress directed the Defense Nuclear Facilities Safety Board (Board) to conduct a study of the adequacy of the K-Area Materials Storage (KAMS) facility and related support facilities at the Savannah River Site (SRS) in South Carolina, in which the Department of Energy (DOE) proposes to store defense plutonium and defense plutonium materials. The statute requires that the Board's study consider the suitability of KAMS and related support facilities, the adequacy of provisions made for remote monitoring and for retrieval of material, and the adequacy of KAMS for plutonium storage beyond the year 2019. Congress also required that the Board include in its report proposals the Board considers appropriate to enhance the safety, reliability, and functionality of KAMS. The report was to be provided both to Congress and to the Secretary of Energy.

1.2 BACKGROUND

In the mid-1990s, DOE developed a well-thought-out plan for storage of its excess plutonium materials. The inventories of materials at the Rocky Flats Environmental Technology Site (RFETS) and SRS were to be stored in a state-of-the-art facility—the Actinide Packaging and Storage Facility (APSF) at SRS. This facility was designed to allow expansion to accommodate additional hazardous materials from other DOE sites. Advanced monitoring and handling features of this facility would have minimized manual inspection and moving of containers, thereby reducing worker dose and criticality risk. In 1998, DOE decided to modify the K-Area reactor, which was built at SRS in the 1950s, to accommodate early deinventory of RFETS. At the time, the KAMS facility was intended to be used for a limited time, less than 10 years, pending completion of APSF.

In 2000, DOE completed a study of plutonium stabilization and storage options.² This study assumed that a proposed plutonium immobilization facility would provide a near-term disposition pathway for DOE's excess plutonium metal and oxides not slated for use in mixed-oxide (MOX) fuel. Given the assumed short storage period, the DOE study team concluded it would be more cost-effective and timely to modify existing facilities to provide the capability for stabilization and storage than to construct a new facility. Accordingly, the recommendation of the study was to cancel the APSF project and modify Building 235-F (235-F), originally built in the 1950s, to install a stabilization and packaging capability. The forwarding memorandum for the DOE study noted that if the immobilization facility were not built, DOE would need to reevaluate the recommendations. The executive summary of that study further stated that DOE would need to construct a storage facility should the immobilization facility not be constructed.

¹ See Appendix D for statutory text of Sections 3181, 3182, and 3183.

² Ref. 1.

Even though APSF had been designed and excavation begun, DOE canceled construction of the facility in 2001. DOE's decision was based primarily on budget constraints and expectations that a disposition path for the plutonium (MOX and immobilization facilities) would be available in the relatively near future. The immobilization facility was delayed shortly after this decision, and then was canceled in 2002. In conjunction with this cancellation, DOE decided that storage of the RFETS plutonium materials in KAMS could extend beyond the 10 years previously estimated. DOE also decided that other sites would continue to store material at their respective sites.

Initially, DOE also planned to utilize APSF to provide a means to stabilize, package, and store SRS's inventory of plutonium. The decision to cancel APSF left SRS without plans for establishing this capability and without clear provisions for storage of its materials. To achieve timely disposition for plutonium at the site, the Board suggested that SRS's plutonium materials could be stabilized and packaged efficiently with some minor modifications to FB-Line.³ SRS agreed, and recently completed modifications establishing a stabilization and packaging capability in FB-Line. Beyond that, SRS concluded that storage of its materials could be provided by modifying storage vaults in 235-F and increasing storage capacity in KAMS.

1.3 SCOPE OF STUDY

At the time Section 3183 was introduced in Congress, DOE intended to store plutonium materials in KAMS. Support activities to be conducted in 235-F included routine inspection of the storage containers packaged in accordance with DOE's plutonium storage standard.⁴ This support from 235-F was necessary because KAMS lacks the necessary safety features to allow opening of the storage packages for inspection and surveillance.

In October 2002, following introduction of Section 3183, DOE's Assistant Secretary for Environmental Management proposed the consolidation of excess plutonium at SRS.⁵ Such consolidation makes it necessary to provide plutonium storage at SRS that exceeds the current capacity of the KAMS facility. DOE's current plan is to use 235-F for this additional storage capacity. DOE is developing plans to store approximately 5,000 packages—containing about 22 metric tons of plutonium—in KAMS, and approximately 2,000 packages—containing about 9 metric tons of plutonium—in 235-F. Several other facilities at SRS will be relied upon to support plutonium storage missions: the FB-Line, Building 772-F, and the Savannah River Technology Center (SRTC).

³ Ref. 2.

⁴ DOE-STD-3013, *Stabilization, Packaging, and Storage of Plutonium-Bearing Materials*.

⁵ Ref. 3.

This Board study assesses the safety of plutonium storage and related activities in all of these facilities. In determining the scope of the study, the Board considered the current inventory of plutonium (both the SRS inventory and additional inventory shipped to SRS from RFETS) and the additional inventory DOE plans to consolidate at SRS.

1.3.1 Current Plutonium Storage

SRS currently stores its plutonium materials in KAMS, FB-Line, and 235-F. The plutonium metal in FB-Line has been packaged to comply with DOE-STD-3013. FB-Line also stores plutonium oxide that has not been stabilized to comply with this standard and is packaged in a variety of configurations. Modifications to FB-Line, completed in October 2003, now provide the capability to stabilize this plutonium oxide material and package them to meet DOE-STD-3013. Once the plutonium materials have been packaged in approved containers, the packages will be moved to either KAMS or 235-F, eliminating the plutonium inventory in FB-Line. FB-Line is not planned to have a plutonium storage mission after 2006.

Most of the plutonium materials in 235-F were shipped to SRS decades ago as part of the Central Scrap Management Office (CSMO) program. This material is currently being characterized item by item in FB-Line for final disposition. These plutonium materials will either be stabilized and packaged in FB-Line to comply with DOE-STD-3013 packaging criteria or be disposed of as waste in HB-Line. In addition to the CSMO materials, several hundred containers of plutonium/uranium composite material recently shipped from RFETS are being stored in 235-F. This composite material is being repackaged into pipe overpack containers (POCs) and is being moved to KAMS.

Plutonium materials currently in KAMS were shipped from RFETS. These materials are in DOE-STD-3013 containers, packed inside Department of Transportation (DOT) Type B 9975 shipping containers.⁶ SRS also stores plutonium-contaminated, highly-enriched uranium (HEU) material from RFETS in KAMS. This material is packaged in sealed, screw-lid containers placed in POCs. Other nuclear materials are stored in KAMS in highly invulnerable encased safes. While this latter material was not the subject of the Board's study, the hazard it poses to the plutonium storage mission was reviewed.

1.3.2 Extended Plutonium Storage

KAMS currently does not have sufficient storage capacity to accommodate extended storage⁷ of the excess plutonium materials from around the DOE complex. Under present plans at SRS, the necessary

⁶ The Nuclear Regulatory Commission's requirements for such containers are found in Title 10 of the Code of Federal Regulations (CFR) Part 71, *Packaging and Transportation of Radioactive Materials*. This packaging configuration is depicted in Appendix C.

⁷ Extended storage and near-term storage are not precisely defined time periods. For the purposes of this report, the Board considers near-term storage covers the next 4 to 5 years. Extended storage is storage beyond that period.

additional storage capacity would be provided by increasing the storage capacity of KAMS and modifying the storage vaults in 235-F. After changes to increase its capacity, KAMS will provide for storage of about 5,000 shipping containers including the POCs.

DOE plans to install storage racks in 235-F to accommodate the remaining materials that cannot be placed in KAMS. The plutonium materials planned for storage in 235-F must be stabilized and packaged in containers meeting DOE-STD-3013 prior to shipment to 235-F. The bulk of the plutonium will be stored in DOE-STD-3013 containers mounted in the new racks; some material will be stored in shipping containers. The planned capacity of 235-F should provide for storage of about 2,000 of the DOE-STD-3013 containers and about 150 shipping containers. In addition, the capacity to store about 40 shipping containers containing neptunium oxide has been maintained in 235-F. Neptunium oxide will be stored for a short period, less than 1 year, pending its shipment to the Y-12 National Security Complex. The neptunium oxide material was not encompassed by this study, but the hazard it poses to the plutonium storage mission was considered. Table 1-1 (on the next page) contains a summary of storage inventory expected after 2006.

1.3.3 Plutonium Storage Support Activities

DOE-STD-3013 requires routine surveillance of containers to assess whether unusual conditions, particularly pressurization or corrosion, are developing. DOT typically requires that Type B shipping containers be inspected at 1- or 2-year intervals, replacing consumable parts (e.g., o-rings), and other parts, as necessary, to maintain their shipping certification. DOE determined that for storage purposes, the refurbishment of the shipping containers could be deferred for at least 10 years without detriment to the package. To confirm that extended storage of material in shipping containers beyond the normal refurbishment time is acceptable, and to support further extension of the refurbishment time, SRS initiated a surveillance program to assess aging and degradation of the shipping container materials. Since KAMS does not have the needed safety systems to allow opening of shipping containers in that facility, these surveillance activities must be accomplished elsewhere on site.

Table 1-1. Approximate Storage Inventory After 2006

Site of Origin and Material	Quantity of Material Storage Containers	
	235-F	KAMS
Savannah River Site <ul style="list-style-type: none"> Plutonium metal and oxide in 3013 containers Neptunium oxide in Type B shipping containers (not included in overall total) 	<p>274</p> <p>40</p>	<p>666 (in Type B shipping containers)</p> <p>N/A</p>
Rocky Flats Environmental Technology Site <ul style="list-style-type: none"> Plutonium metal and oxide in 3013 containers Plutonium-contaminated highly-enriched uranium metal HEU/plutonium metal and plutonium composites 	<p>N/A</p> <p>N/A</p> <p>N/A</p>	<p>1,750 (in Type B shipping containers)</p> <p>500 (in POCs)</p> <p>200 (in POCs)</p>
Lawrence Livermore National Laboratory <ul style="list-style-type: none"> Plutonium oxide in 3013 containers 	<p>N/A</p>	<p>115 (in Type B shipping containers)</p>
Los Alamos National Laboratory <ul style="list-style-type: none"> Plutonium metal and oxide in 3013 containers 	<p>N/A</p>	<p>96 (in Type B shipping containers)</p>
Hanford <ul style="list-style-type: none"> Plutonium metal and oxide in 3013 containers 	<p>1,050</p>	<p>1,500 (in Type B shipping containers)</p>
Total	<p>1,324</p>	<p>4,827</p>

Source: Ref. 4.

N/A not applicable

SRS plans to perform the inspection and surveillance activities in FB-Line until needed modifications to 235-F have been completed. FB-Line has the capability to enable opening of the shipping containers and has recently established the capability to stabilize and repackage any container exhibiting unusual conditions. DOE's desire to shut down FB-Line leads to the need to reestablish elsewhere the capability to perform surveillance and monitoring, as well as stabilization and packaging. SRS has begun planning modifications to 235-F to establish this capability. These modifications are expected to be completed in 2005, by which time DOE expects FB-Line to be deinventoried.

Several additional analytical functions are needed to support storage of this material. SRS must be able to analyze plutonium material and containers exhibiting unusual conditions during surveillance or inspection. SRS currently plans to perform any needed analysis of materials in Building 772-F or at the SRTC.

1.3.4 Facilities Reviewed

Based on the above discussion, it is clear that three facilities at SRS have a near-term or extended storage mission or serve needed support for storage—KAMS, 235-F, and FB-Line. Building 772-F and SRTC provide an analytical support function. Therefore, this study addressed the adequacy of plutonium storage and related activities in all five of these facilities. The Board's study took into account each facility's remaining mission and its role in safe storage of plutonium at the site.

1.4 STUDY ASSUMPTIONS

There are many safety programs that contribute to safe storage that were not specifically reviewed for this report, for example, radiological protection, criticality prevention, quality assurance, emergency preparedness, on-site fire department, and training. These programs have been reviewed in the past in conjunction with the Board's ongoing evaluation of activities at SRS. For purposes of this study the Board assumed that SRS will maintain an acceptable site safety infrastructure to support the storage mission.

SRS also has the ability to analyze plutonium samples and perform metallographic analysis as needed. SRS is expected to maintain the analytical capability to analyze plutonium and perform required inspections in the future.

1.5 STUDY APPROACH

Integrated Safety Management principles guided this study. The scope of the mission was determined, the hazards characterized, and the adequacy of the safety controls assessed. Initially, the safety bases for KAMS, 235-F, and FB-Line were reviewed for their adequacy to protect the public, workers, and environment.⁸ From safety basis

⁸ The safety basis means the documented safety analysis (DSA) and hazard controls that provide reasonable assurance that a DOE nuclear facility can be operated safely in a manner that adequately protects workers, the public, and the environment. [10 CFR 830, *Nuclear Safety Management*.]

documentation it is possible to identify safety-related structures, systems, and components (SSCs) for further evaluation. The safety basis documents do not currently cover some of the support activities outlined above (e.g., stabilization and packaging in 235-F). In such cases, the Board evaluated SSCs typically required for a facility with a limited processing and storage mission.

For two facilities—KAMS and 235-F—the expected storage missions may be more than 20 years. For these facilities, the Board’s evaluation of the SSCs entailed an assessment of the qualified operable life of the safety systems, that is, whether the systems can be relied upon to perform safety functions for the facility’s remaining operating life. An initial comparison was made of the existing design configuration for the SSCs measured against current design codes and standards. The evaluation of safety systems in FB-Line also entailed an assessment of the operability of the SSCs. However, due to the expected short remaining storage mission for FB-Line, comparison of the design of needed SSCs against current design codes and standards was not considered useful. Significant upgrades to the design could not reasonably be made during the remaining short life of the facility. Should DOE decide to extend the mission of FB-Line, design upgrades may be needed.

Building 772-F and SRTC have a possible support mission. That support may include some of the surveillance activities required by DOE-STD-3013 or analysis of containers appearing to be in an unusual condition. Analysis of the plutonium may be needed in such cases. Since plutonium materials will not be stored in these facilities for lengthy periods, a detailed evaluation was not necessary. The Board will review these facilities as necessary in the course of its regular oversight of SRS. Accordingly, the study focused on the current capability to analyze plutonium samples and whether that capability was sufficient.

Table 1-2 depicts the study approach discussed above. The operability and design of safety-related SSCs were assessed for adequacy to protect the public, worker, and environment as indicated in the table.

Table 1-2. Study Approach

Facility (Function)	Safety Basis Assessment	Operability Assessment	Design Assessment	Other Assessment
KAMS (extended storage)	U	U	U	
Building 235-F (extended storage, packaging and surveillance support)	U	U	U	
FB-Line (near-term storage, packaging and surveillance support)	U	U		
Building 772-F and/or Savannah River Technology Center (plutonium analysis capability)				U
All storage facilities (remote monitoring and retrieval capability)				U

A special consideration in formulating the study approach was the issue of management of facility aging. Managing the effects of aging on a facility’s SSCs requires a systematic approach and evaluation. An integrated and continuous program of predictive and preventive maintenance, inspection and monitoring, and repair and replacement can ensure that the SSCs perform as designed for as long as needed. The initial step of such a program is to identify safety-related SSCs that must remain functional during normal operation, and during and following design basis accidents or events.⁹ The program then determines which of those safety-related SSCs are subject to aging effects. Some of these SSCs, such as the facility’s structure, may be passive; others are active, such as ventilation system fans that are prone to wear. Analyses and engineering evaluations are performed to determine reasonable actions needed to ensure that the SSCs continue to perform. These actions are carried out through the facility maintenance program.

⁹ Design basis accidents are accidents postulated for the purpose of establishing functional and performance requirements for safety SSCs. [DOE-STD-3009-94, *Preparation Guide for U.S. Department of Energy Nonreactor Nuclear Facility Documented Safety Analyses.*]

2. CONCLUSIONS AND PROPOSALS

This section presents the conclusions of the Board's study and proposals for enhancing the safety, reliability, and functionality of plutonium storage facilities at SRS. Supplementary information on the technical basis for the conclusions and proposals presented here can be found in Appendices A and B.

2.1 PLUTONIUM DISPOSITION PROGRAM

During the past decade, DOE has significantly changed its plans for how to stabilize and store excess plutonium. Originally, DOE proposed and designed a state-of-the-art facility (APSF) to safely store and monitor all excess plutonium for an indefinite time period. Also planned was a proposed plutonium immobilization facility to provide a near-term disposition pathway for excess plutonium not designated for MOX fuel.

Instead of proceeding with these specially-designed, modern facilities for stabilization, packaging, and storage of plutonium, DOE now proposes to rely on a combination of 50-year-old facilities that currently do not meet modern safety standards. This lack of careful, consistent planning has forced the site chosen for storage, SRS, to focus on what can be done with existing facilities, foreclosing options that may have been both cost-effective and safety-conscious. Past decisions were based on a plutonium storage study¹⁰ that itself was based on assumptions no longer consistent with present circumstances.

Moreover, the current plan is risky: it depends on the successful licensing and construction of the MOX Fuel Fabrication Facility for disposal of the bulk of excess plutonium. Even if the MOX Fuel Fabrication Facility is successful, DOE has not completed a disposition plan for excess plutonium not expected to be processed into MOX fuel. DOE is still assessing its excess plutonium inventory to determine its suitability for MOX fuel. Currently, there is approximately 5 metric tons of plutonium that is not considered suitable for MOX fuel. This quantity of plutonium could change as DOE declares more plutonium as excess or as MOX fuel requirements are refined. The SRS plutonium storage plans were based on an assumption that the immobilization and MOX facilities would provide a near-term disposition path for all the excess plutonium metal and oxide. With that secure extended outlook, the storage and stabilization plans sensibly focused on using existing facilities. For a near-term storage mission, such an approach can perhaps be justified; however, for extended storage this approach presents a number of potential safety problems.

DOE recognizes the importance of establishing a disposition path, and to that end formed a team in 2002 to determine a disposition path for material not planned for MOX fuel. Unfortunately, progress made on this task has been slow. So far, no technically feasible path forward has been approved. DOE needs to expedite this task to preclude unnecessary extended storage of plutonium at SRS.

¹⁰Ref. 1.

Pending disposition of excess plutonium, DOE is planning to consolidate plutonium at SRS. In the Board's view, DOE would benefit by conducting an integrated study of options for storage of plutonium at SRS. The study should consider the widest possible range of factors including safety, environmental impact, national security, cost, and schedule. Among the options that might be considered are the following:

- ! Construction of the already-designed APSF facility. Some design changes might be warranted to enable better integration with the Pit Disassembly and Conversion Facility (PDCF) and MOX facilities.
- ! Modification of PDCF to accommodate increased storage. PDCF will have some storage capability and could be expanded to accommodate all of the plutonium to be stored at the site. The PDCF design already includes a stabilization and packaging capability. A realistic assessment of the programmatic risk of PDCF not being constructed is an essential element of this option.
- ! Installation of safety systems (e.g., fire protection, filtered ventilation) sufficient to allow storage of all excess plutonium in KAMS. With such systems available, the need to store plutonium in shipping containers may be obviated, thus allowing increased storage capacity. An inspection capability and a small plutonium stabilization and packaging capability could then be added to a suitable adjoining area. This capability would preclude shipping plutonium containers to another facility for inspection and having to maintain this facility.

Each of these options, unlike the current baseline, would result in plutonium storage at the site in one facility with the capability to perform all of the operational functions required for storage. Utilization of only one facility should reduce intrasite movements of plutonium and lower operating costs, particularly costs associated with safeguards.

Proposals:

1. Expedite the development of a complete, well-considered plan for the disposition of all excess plutonium to preclude unnecessary extended storage of plutonium at SRS.
2. Conduct a new study of available options for the storage of plutonium at SRS.

2.2 SUITABILITY OF FACILITIES

2.2.1 K-Area Materials Storage Facility

The K-Reactor was constructed in the 1950s and operated through the early 1990s. The reactor was then decommissioned and the fuel removed, along with most of the equipment previously needed for reactor operations. DOE then modified the reactor confinement area and adjacent areas to form a large warehouse now called the Material Storage Area (MSA).

Before plutonium is placed in the MSA, it must be stabilized and packaged in accordance with DOE's plutonium storage standard.¹¹ Stainless steel weld-sealed containers, one nested inside the other, are used to meet this standard.¹² The container is then overpacked in a shipping drum that meets DOT requirements. Shipping drums are stacked two and three high throughout the MSA.

In a general sense, the KAMS facility is a robust structure that can be made suitable for extended storage of plutonium. Its most significant drawback is the lack of safety systems to support handling of material containers not held in DOT-certified shipping drums. The facility is not equipped to repair damaged containers, conduct needed surveillance and inspections of storage packages, or stabilize and repackage material. These essential activities must be performed in another facility. This drawback creates the need for using multiple SRS facilities and for moving plutonium packages from one to the other, posing additional risk to the workers and the public. Enhancing the KAMS facility with safety systems sufficient so that all storage activities could be performed in it should be considered as an option in the plutonium storage study proposed above.

Fires are the most significant accidents of concern in the KAMS facility, yet it lacks fire protection systems required by DOE for nuclear facilities. DOE has attempted to justify this situation by analyzing the safety impacts of credible fires¹³, rather than by bringing the facility into compliance with fire protection requirements. Such an approach is inconsistent with long-standing DOE policy to adopt best-in-class fire protection for its most hazardous facilities. Moreover, DOE has chosen not to remove unnecessary combustible materials, and instead has taken mitigative measures of questionable fire safety efficacy.

Proposal: Install fire protection systems and eliminate unnecessary combustibles in KAMS.

2.2.2 Building 235-F

Building 235-F is a reinforced concrete structure built in the late 1950s. Initially, it was used for plutonium processing, fabrication of targets for the reactors, and plutonium storage. In the 1970s, the facility was modified to accommodate fabrication of heat sources using plutonium-238. For the last 20 years, the facility has been used only for storage; DOE expected to decommission it. Safety systems such as fire protection and criticality alarms that were not needed at the time were deactivated and removed.

Building 235-F has not been evaluated by DOE for extended plutonium operations; most likely, substantial modernization will be required. The safety basis for the facility must be updated and equipment needed

¹¹ DOE-STD-3013, *Stabilization, Packaging, and Storage of Plutonium-Bearing Materials*.

¹² Schematics and a photograph of this container are provided in Appendix C.

¹³ A credible fire is the largest fire to be expected taking into account fixed and transient combustibles and passive fire protection features such as fire area boundaries.

to stabilize and package plutonium must be installed. Many deficiencies in existing safety equipment will require correction. For example, the lightning protection system does not comply with current industry standards, and safety-related instrumentation and control systems do not meet requirements for electrical and physical separation and are vulnerable to single-point failure. The majority of the electrical cables in 235-F are approximately 50 years old and have exceeded their estimated design life. Furthermore, safety systems such as fire protection and criticality alarms that have been removed will likely need to be reinstalled for an extended mission. Fire protection systems would have to be based on a new fire hazards analysis (FHA) that considers the facility's modified mission.

To assess these deficiencies, DOE should conduct a systematic evaluation of the facility's safety-related systems. The U.S. Nuclear Regulatory Commission implemented a Systematic Evaluation Program (SEP) for evaluation and relicensing of older commercial nuclear power plants. The SEP approach involved conducting a systematic and integrated review to compare existing design features of the SSCs against those that would be required by today's standards. In the early 1990s, the Board recommended that DOE take such an approach for resumption of operations at the Rocky Flats Plant (now RFETS).¹⁴ DOE expanded the scope of this recommendation to include the K-Reactor at SRS when this reactor was being planned for restart. The program was subsequently dropped when DOE decided to shut down the reactor permanently. At a minimum, this evaluation should include the ventilation systems; the fire protection systems; electrical systems, including lightning protection; and the required instrumentation and control systems.

Most of the safety-related SSCs in facilities planned for storage at SRS were designed and placed in operation long before today's technical standards and criteria had been developed. The SEP's engineering evaluations of the gaps between existing design features and those required by current standards would help determine appropriate improvements to the SSCs to enhance safety and better ensure the SSC's continued reliability. The evaluation should identify gaps or aspects of the existing system design that do not meet current design requirements. A rigorous evaluation of the safety benefit of upgrading the systems to comply with current design requirements should be completed. Also, the condition of safety-related cables should be determined using a suitable monitoring system. DOE should also assess the existing electrical system for 235-F against current National Electric Code (NEC) requirements using a NEC-qualified inspector to identify potential fire hazards and understand latent system vulnerabilities. Such assessments are performed routinely for the commercial nuclear industry and have been conducted for other facilities at SRS.

Other safety concerns will have to be analyzed. The structural analysis of record for 235-F is inadequate by today's standards and acceptance criteria, and needs to be redone. Results of recent geologic testing have identified soft zones beneath a portion of the facility. The structural analysis needs to establish whether these soft zones could cause unacceptable subsidence of portions of the facility during an

¹⁴ Recommendation 90-5, *Systematic Evaluation Program at Department of Energy's Rocky Flats Plant*, issued May 17, 1990.

earthquake. Residual plutonium-238 in unused process cells in the building should be removed now rather than accepted with its attendant hazards for the duration of the storage mission.

DOE should carry out its plan to remove and characterize plutonium materials currently stored in 235-F. DOE should not plan extended storage of plutonium in 235-F until it has completed implementing the proposals in this report. It may be preferable from safety, cost, and mission perspectives to pursue storage elsewhere at SRS. Options include an enhanced KAMS facility, a new storage facility, or an expanded PDCF.

Proposals:

1. Establish an acceptable safety basis for stabilization and packaging of plutonium and extended storage of plutonium in the facility.
2. Conduct a systematic evaluation of the safety systems to determine needed upgrades.
3. Perform a structural analysis assessing seismic adequacy measured by current acceptance criteria. Since the facility has a new extended mission, the structural analysis should be based on a ground motion equivalent to that used in the analysis for a new facility at SRS.
4. Decontaminate unused process cells.

2.2.3 FB-Line

FB-Line can complete safely its stabilization and packaging mission. Appropriate readiness reviews for startup of the new plutonium stabilization furnaces and packaging system have been completed.

2.2.4 Building 772-F and Savannah River Technology Center

These facilities have adequate analytical capabilities to support the plutonium storage mission at SRS. These analytical capabilities will need to be maintained throughout the storage mission.

2.3 REMOTE MONITORING AND RETRIEVAL OF MATERIAL

Neither the KAMS facility nor 235-F are equipped to provide remote monitoring of the physical condition of stored material. Remote monitoring capability has been provided for security purposes, such as video cameras and electronic tamper indicating devices. Such monitoring warns of removal of or tampering with storage packages but does not provide information on the condition of the contained materials. Periodic physical inspections of material packages are planned to confirm the safe storage of the contained materials.

Retrieval of material from either the KAMS facility or 235-F should not present a problem. The plutonium material will have been stabilized and packaged into robust containers complying with DOE's plutonium storage standard. These containers can easily be inserted into shipping containers. Material stored in KAMS will already be in shipping containers or other containers suitable for intrasite shipments. Other than being moved to a disposition facility, the material will generally not be moved from KAMS except as needed to handle a damaged container or for routine inspections and monitoring. SRS has not yet developed and validated the plan for handling, moving, and shipping a damaged, potentially contaminated container from KAMS.¹⁵

Proposal: Develop and implement validated procedures for the handling and intrasite shipment of plutonium containers, including damaged containers.

2.4 ADEQUACY OF FACILITIES BEYOND 2019

Once the existing SRS facilities have been made adequate and thus can be expected to safely perform storage and processing missions, use of the facilities beyond 2019 becomes a problem in management of the facility's aging. SRS has established a program for managing facility aging that consists of preventive, predictive, and corrective maintenance. The site's program for predicting problems with safety equipment before failure is particularly noteworthy. SRS's approach to managing aging of its facilities can be expected to maintain needed safety systems for plutonium storage and handling. To ensure that these facilities can be used safely beyond 2019, the current performance of the maintenance program must continue. The frequency of maintenance and the cost of maintaining safety equipment in these facilities can be expected to increase with time, and may become prohibitive.

¹⁵ FB-Line will be the receiving facility for the next several years.

APPENDIX A

STUDY FINDINGS

This appendix presents additional information on topics covered in the study. The information in this appendix is derived from reviews conducted on-site by the Board's staff.

A.1 SUITABILITY OF FACILITIES

A.1.1 Safety Bases and Hazard Controls

DOE issued a nuclear safety rule in January 2001 to establish the requirements for safety basis documents.¹⁶ The safety basis is established in the DSA for existing facilities.¹⁷ The contractor at SRS has submitted rule-compliant DSAs to DOE's Savannah River Operations Office (DOE-SR) for the facilities of interest to this study.

However, the safety bases for KAMS, 235-F, and FB-Line do not account for some of the future activities needed to support the extended storage of plutonium. These activities include storing DOE-STD-3013 containers, adding stabilization and packaging processes, and limited sampling capability. Furthermore, the duration of the planned storage mission for KAMS significantly exceeds the 10 years originally expected, and the process equipment for high-temperature stabilization of plutonium oxides was still being added to FB-Line when its safety basis was prepared. The changes to the safety bases for KAMS and FB-Line needed to account for these storage activities should not be significant, but major changes to the safety basis of 235-F are likely to be required.

The safety objective for all nuclear facilities is the prevention of releases of nuclear material (particularly a release of plutonium) and radiation exposure to workers. Initiating events that can lead to these harmful effects are generally categorized as follows:

- ! Natural phenomena (earthquake, hurricane, tornado, flood, lightning)
- ! Loss of confinement or containment¹⁸
- ! Fires and Explosions

¹⁶ 10 CFR Part 830, *Nuclear Safety Management*.

¹⁷ "Documented safety analysis means a documented analysis of the extent to which a nuclear facility can be operated safely with respect to workers, the public, and the environment, including a description of the conditions, safe boundaries, and hazard controls that provides the basis for ensuring safety." [10 CFR 830.3]

¹⁸ Containment does not allow any release of the hazardous material from its container (e.g., building or DOE-STD-3013 container), while confinement allows for a release through appropriate filters (e.g., High-Efficiency Particulate Air [HEPA] filters).

- ! Criticality
- ! Externally-generated damage (e.g., aircraft impact)
- ! Direct radiation exposure

For the facilities of concern to this study, adequate protection of the public, workers and the environment is fundamentally provided by the following safety systems, in conjunction with several safety management programs:

- ! A structure that can withstand natural phenomena and man-made hazards
- ! A confinement or containment system for the nuclear material
- ! A fire protection system to help protect these two systems
- ! Electrical power, and instrumentation and control systems that support these systems

Two key safety management programs, maintenance and worker protection, were evaluated in the course of this study because of their importance to an extended storage mission. While these reviews focused on the above safety systems and safety management programs, numerous other safety programs (e.g., criticality safety, radiation protection, quality control, configuration management) and site infrastructure capabilities (e.g., fire department, on-site transportation) must be maintained to ensure safe storage of materials. This study did not specifically evaluate these other safety programs or site infrastructure capabilities. The Board has determined that these programs are acceptable during the course of safety evaluations previously performed at SRS.

A.1.2 K-Area Materials Storage Facility

Safety Basis. The draft DSA for KAMS had been submitted to DOE-SR at the time of the Board's on-site review, and was subsequently approved by DOE without significant changes. The Board reviewed this draft document since it was pertinent to the facility's mission of extended storage of plutonium materials. Because KAMS lacks confinement features, the draft DSA was based on the assumption that a release of plutonium material in the facility would have unacceptable consequences. Accordingly, the draft DSA requires plutonium materials to be stored in containers compliant with DOE-STD-3013 and enclosed in Type B shipping containers (e.g., Type B 9975 containers) meeting Nuclear Regulatory Commission requirements¹⁹ for off-site shipment. The draft safety basis did not allow opening of containers in the facility, nor did it allow for inspection of the contents of the containers. These limitations resulted from the facility's lack of a HEPA filter ventilation system; any release of material within the facility would be vented directly outside.

¹⁹ See 10 CFR Part 71, *Packaging and Transportation of Radioactive Materials*.

The draft DSA allows storage of a small quantity of HEU, HEU contaminated with plutonium, and other nuclear materials. While the consequences from a release of HEU or the other nuclear materials are not as great as those from a release of plutonium-bearing materials, the draft DSA requires that the HEU and other nuclear materials also be stored in suitably robust containers to prevent a release.

The draft DSA used the methodology described in DOE-STD-3009-94, *Preparation Guide for U.S. Department of Energy Nonreactor Nuclear Facility Documented Safety Analysis*, to identify and analyze the hazards and needed controls. The most hazardous event in this facility is postulated to be a major fire that jeopardizes the integrity of the shipping containers, potentially releasing plutonium to the environment. The accident consequence analysis presented in the draft DSA indicated that the release of the contents of two or more storage containers during such a fire would result in off-site consequences exceeding DOE's evaluation guideline of 25 rem. Such a release would require highly reliable safety controls to prevent or mitigate the hazard. The majority of controls for material storage identified in the draft DSA related to protection against such fires.

Natural Phenomena Hazards. The KAMS facility is a robust, reinforced concrete structure that is embedded 40 feet into the ground. The MSA, where the plutonium is stored, encompasses the old Process, Crane Wash, Crane Maintenance, and Stack Areas. It consists of two structurally-independent buildings: the Process Building (Process, Crane Wash, and Crane Maintenance Areas) and the Stack Building. These buildings as well as adjacent buildings are separated by expansion joints that allow independent movement and minimize the interaction of structures during a seismic event.

The structures and components that compose the storage area were classified as Performance Category (PC)-3 in accordance with DOE design standards.²⁰ Adjacent equipment or structures with less stringent performance criteria that could adversely affect the performance of the storage areas during a seismic event were identified and analyzed to PC-3 criteria. For example, an adjacent building housing the exhaust fans is qualified for PC-2 but was evaluated to PC-3 criteria to address concerns regarding seismic interaction. Equipment inside the MSA that did not meet PC-3 criteria was removed.

The KAMS structural analysis of record was completed in 1999. This analysis adequately documents the acceptability of the existing structures. The seismic evaluation used standard analytical models and methods of analysis. The facility structure can withstand possible natural phenomena events.

Loss of Containment/Confinement. Because the HEPA filters in the KAMS ventilation system have been removed, this system does not provide confinement for the nuclear materials stored in the facility.

²⁰ Performance categories are a classification system used to ensure that specified performance goals are met during natural phenomenon events. Five performance categories, ranging from 0 to 4 in order of increasing level of protection, are defined in DOE-STD-1021, *Natural Phenomena Hazards Performance Categorization Guidelines for Structures, Systems, and Components*.

Instead, KAMS relies on the safety-class DOE-STD-3013 containers enclosed in DOT Type B shipping containers to provide this function. This a very robust packaging configuration. The Type B shipping containers are qualified to resist damage during transportation and handling, and their robust design is a credited safety feature for protection of the workers. Appendix C shows a typical example of this packaging configuration.

Other than a major facility fire, discussed below, the most plausible event that could breach these containers would be accidental puncturing by a forklift. This event is prevented through an engineered control to limit the speed of the forklift, along with modification of its lifting tines to make them incapable of penetrating a storage container.

Externally Generated Hazards. The hazard analysis performed by the site for externally generated events was adequate. The facility’s structure, limited over-flights, and remote location, in conjunction with maintaining a viable site-wide emergency response capability, provide adequate controls for such hazards.

Fire Hazards. As noted above, the event with the greatest off-site consequences was postulated to be a major fire threatening the integrity of the shipping containers, potentially releasing plutonium into the environment. Accordingly, the majority of the controls identified in the draft DSA related to protection of the containers against such fires.

Even though fire is the dominant hazard, KAMS has no automatic fire suppression or detection systems and only a partial fire department standpipe system to facilitate manual firefighting. DOE Order 420.1A, *Facility Safety*, would normally require automatic suppression or detection as a defense-in-depth feature of a conservative fire protection program. The KAMS FHA relies on a single level of protection—fire barriers—to protect the plutonium from a fire outside the MSA. Ventilation in conjunction with administrative controls on the quantity and locations of combustibles compose the single level of defense to protect the plutonium from a fire inside the MSA. Failure of any one of these systems to perform as required could result in a fire that would threaten the stored materials.

The limiting-case fire scenario inside the MSA results from sequential burning of several forklifts. The thermal analysis and the DSA credited one of two exhaust fans in the ventilation system to be operating during this event. The fan draws air through the MSA during the postulated fire to prevent the shipping containers from exceeding their qualified temperature. With this strategy, the ventilation fans would normally be required to be designated as safety-class equipment. The DSA, however, identified the ventilation flow monitors as the only safety-class equipment to be maintained by Technical Safety Requirement (TSR) controls.²¹ Similarly, there are no TSR controls governing

²¹ “Technical Safety Requirements means the limits, controls, and related actions that establish the specific parameters and requisite actions for safe operation of a nuclear facility and include, as appropriate for the work and the hazards identified in the documented safety analysis for the facility: safety limits, operating limits, surveillance requirements, administrative and management controls, and use and application provisions, and design features as well as a bases appendix.” [10 CFR 830.3]

operability of fan suction pressure gauges that provide a backup to the flow monitors.²² Subsequently, DOE indicated that DOE-SR had directed the contractor at SRS to establish facility conditions that do not require exhaust ventilation at any time.²³

To maintain air flow through the facility needed to mitigate the effects of the limiting-case fire inside the MSA, a roll-up door between the outside and the MSA was required to be fixed in the open position. Temperature extremes during winter and summer or adverse weather conditions (e.g., hurricanes, tornados) could affect the storage environment and the habitability of the MSA. DOE does not have a plan to cope with changing ambient conditions. Installation of a fire protection system would obviate the need for this door to remain open.

The limiting-case fire outside MSA results from burning of cables and other equipment that were abandoned in-place in the actuator tower, above and adjacent to the MSA. The FHA and draft DSA concluded that the cables and equipment could burn uncontrolled without threatening the stored plutonium, provided a 40-square-foot opening is cut into the roof of the space to allow venting of heat and the products of combustion, and that fire-resistant coating is applied on structural beams in the space to protect them from overheating and losing structural strength. For an extended storage mission in this facility, the cables should be removed.

The short-circuit analysis for KAMS was based on the short-circuit currents from the original electrical configuration of the K-Reactor. Because there have since been major equipment modifications, including removal of many of the electrical loads, the short-circuit analysis needs to be redone using short-circuit currents based on the existing configuration of the electrical distribution system. Such an evaluation would verify the capability of the electrical equipment to perform safely without initiating a fire or an explosion.²⁴

Based on these considerations, DOE should:

- ! Provide an automatic fire suppression and fire alarm system to provide defense-in-depth. As an alternative, provide an automatic detection and alarm system and enhanced manual firefighting capability.
- ! Determine if the mission is considered “vital” under DOE Order 420.1A, *Facility Safety*, and establish the unacceptable program interruption period.²⁵

²² The Board disagreed with this approach and requested clarification from DOE. Ref. 5.

²³ Ref. 7.

²⁴ The Board has transmitted this concern to DOE. Ref. 6. At the time of this report, DOE has not responded to the Board’s letter.

²⁵ Under DOE Order 420.1, when the mission of a facility is considered to be “vital” and an unacceptable program interruption period is determined, fire protection measures must be taken to ensure that fire damage cannot credibly create a longer program interruption.

- ! Reevaluate the short-circuit analysis for the electrical system using short-circuit currents based on the existing configuration of the electrical distribution system.

Explosions. The hazard analysis for explosions performed by the site was adequate. There are no postulated explosions in this facility that could lead to a release of material.

Direct Radiation Exposure. The hazard analysis performed by the site for direct radiation exposure hazards from current materials was adequate. The site must maintain a radiation protection program compliant with DOE requirements, in conjunction with its worker protection program, to ensure adequate protection from radiation.

The site does not appear to have addressed thoroughly the potential radiation exposure hazards from higher-activity materials shipped from other sites—in particular material from Hanford. A significant quantity of the Hanford plutonium is reactor-grade, thus more radioactive than the weapons-grade plutonium presently stored in KAMS. The site’s radiation protection experts should conduct an as-low-as-reasonably-achievable (ALARA) review²⁶ to determine appropriate safety measures for handling and storage of high-radiation materials. Such a review would help identify reasonable measures to protect workers.

Nuclear Criticality. The analysis of potential criticality events in KAMS performed by the site is adequate.²⁷ As long as the spacing of plutonium material provided by the shipping containers is maintained, and no plutonium processing activities are allowed, accidental criticality in this facility is not possible.

Worker Protection and Maintenance Programs. The worker protection program is considered adequate. The maintenance program is also adequate and a mature program as discussed in section A.3.

A.1.3 Building 235-F

Safety Basis. The safety basis document for the 235-F facility is based on work done in 1989 using then-applicable DOE requirements. This document has been revised several times since then and supplemented by a hazard analysis performed in December 2002. The combined set of documents was approved by DOE-SR in January 2003 as a rule-compliant DSA for this facility.

The original safety basis was prepared using the management oversight risk tree (MORT) methodology for identification and analysis of the hazards. The MORT methodology is not a systematic process hazard

²⁶ ALARA is the approach to radiation protection to manage and control exposures to the work force and to the general public to as low as is reasonable, taking into account social, technical, economic, practical, and public policy considerations. [10 CFR 835, *Occupational Radiation Protection*]

²⁷ The Board has previously concluded that the site’s criticality safety program was adequate.

analysis and is based on segmentation of the operations and identification of bounding events. Although this document was supplemented by a more recent hazard analysis, the combined safety basis is still based on a methodology inconsistent with 10 CFR Part 830 because it does not analyze operational events using a deterministic approach. Instead, a frequency-based cutoff is used to screen out accident scenarios. Furthermore, the unmitigated accident analysis, used for identification and classification of safety controls, calculates consequences using “average” or “best estimate” values of the parameters crucial to the dose estimates. More conservative, upper-bound values should be used for this analysis. Finally, the analysis calculates the consequences to the public in terms of person-rem as opposed to the maximum dose to a member of the public at the site boundary for unmitigated releases. Evaluating consequences in this manner is not consistent with the DOE requirements provided in 10 CFR Part 830.

The existing safety basis for 235-F is also unsatisfactory in that it uses probabilistic arguments to assert the operability of systems and components that are not qualified to function during the design basis accidents. For example, it associates the probability of survival for the ventilation tunnel to the sand filter (not qualified to survive a design basis earthquake) during a seismic event, and therefore does not account for an unfiltered release after an earthquake. This approach is not consistent with DOE directives that require controls credited for preventing or mitigating an accident to be designed and maintained as safety systems to ensure their operability.

The approved safety basis of this facility allows for limited activities in support of plutonium storage at SRS. Mainly, it permits storage of a limited number of shipping containers in the storage vaults and repackaging of containers to the extent that the inner cans are not opened. Functions needed to support consolidation of plutonium at SRS including storage of an additional 2,000 containers (DOE-STD-3013 containers), opening of the containers, sampling, and stabilization processing, are not analyzed in these safety basis documents. To provide an adequate safety basis for these operations, DOE needs to (1) perform a thorough hazard analysis of these activities consistent with requirements of 10 CFR Part 830 and site standards, (2) identify and classify all the necessary controls, and (3) implement the new controls before the facility is authorized to fulfill its future mission. Preparation of a new safety basis for these activities should be integrated with a new FHA and criticality safety evaluation supporting the facility’s new mission.

Natural Phenomena Hazards. Building 235-F is a reinforced concrete structure built in the early 1950s. The exterior walls of the two-story structure are 14 inches thick, the floor slabs 8 inches thick, with the first floor being a slab on grade. A reinforced-concrete ventilation duct 14 inches thick and process cells were added circa 1973–1974 as part of the Plutonium Fuel Form (PuFF) facility installation. The duct is anchored to the roof slab and extends the length of the roof and down the west wall of the building.

The structural analyses of record for 235-F are outdated, lacking both the rigor and the acceptance criteria that would be required today. For example, the seismic analyses were based on an outdated seismic ground motion that is less conservative than requirements contained in DOE-STD-1020-2002, *Natural Phenomena Hazards Design and Evaluation Criteria for Department of Energy Facilities*. Moreover,

the acceptance of structural elements was based on American Concrete Institute (ACI) 318, *Building Code Requirements for Structural Concrete*, intended for use in conventional, non-nuclear facilities. A nuclear facility such as 235-F would be expected to meet the more stringent structural requirements of ACI 349, *Code Requirements for Nuclear Safety-Related Concrete Structures and Commentary*.

Two soil soft zones were recently identified by SRS during subsurface exploratory work near 235-F, one being 4 feet thick and the other 6.5 feet thick. Both soft zones were discovered in the same testing location, at depths of approximately 122 feet and 150 feet, respectively, below the ground surface, on the southwest side of the building. The extent and properties of the soft zones have not been fully characterized because of the limited amount of exploration in the immediate vicinity of the building. Soft zones can lead to large differential settlements during a seismic event. The settlement calculations of record do not consider these soft zones.

A structural evaluation of the building needs to be completed to current standards before the Board can evaluate the adequacy of the structure for extended storage. The potential hazards associated with the soft zones discovered beneath the building could be of sufficient magnitude to cause the building to be inadequate for the proposed mission.

The current lightning protection system provides protection by using the building's interconnected structural steel rebar as a lightning boundary. However, the existing arrangement has been rendered ineffective by unbonded metallic penetrations that breach the boundary. By attaching to an unbonded rooftop or high-elevation penetration, lightning energy (capable of igniting in-situ combustibles) could couple directly into the facility, bypassing the rebar boundary altogether. Given the lack of viable fire suppression capabilities in 235-F, DOE ought to install a lightning protection system compliant with National Fire Protection Association (NFPA) Standard 780, *Standard for the Installation of Lightning Protection Systems*.²⁸

Loss of Containment/Confinement. Protection of the public against hazards posed by the operation of Building 235-F is provided mainly by confinement. Confinement of nuclear material is accomplished by the facility structure, ventilation tunnels, and by the sand filter which is designed to filter any release of material before reaching the environment.

The ventilation system was modified in the mid-1980s when it was separated from the F-Canyon exhaust system. At that time, a new sand filter and new exhaust fans were installed. While evaluating 235-F, the Board found the majority of the ventilation system to be in good condition, but some ventilation hardware throughout the facility were in poor condition. Several ventilation grills were capped off or plugged in the vestibule area and Actinide Billet Line room; it is uncertain whether any justification for these modifications exists. Also, construction doors providing access to the safety-class exhaust tunnel on the roof of 235-F are in poor condition.

²⁸ Ref. 6.

The safety basis for 235-F designates the ventilation system as needed to confine the hazards and direct them away from facility workers. The exhaust tunnel interlocks are currently designated as safety-class in preventing the release of legacy radioactive material to the environment. There are also safety-significant interlocks to start the standby filter exhaust fans should the ventilation system tunnel lose negative pressure. These instruments were designed to older Dupont standards that permitted the use of non-safety wiring for safety instruments if the controlled component failed in the safe condition on loss of signal or power. Institute of Electrical and Electronics Engineers (IEEE) STD 384, *Criteria for Independence of Class 1E Equipment and Circuits*, prohibits this practice because failure of non-safety wiring could prevent safety actions. The instruments themselves do not meet single-failure and separation criteria for safety-related equipment; they use the same sensing line and are not physically separated as required. If the 235-F safety analysis for storage and related activities requires safety-class exhaust tunnel interlocks, the associated controls for the system will need to be upgraded to be consistent with DOE directives and guidance.

One of the most significant hazards in 235-F results from about 700 grams of plutonium-238 residue in ventilation ducts and process cells in the PuFF. This material could be released during a fire, seismic event, or through deterioration of seals in the process cells. Decontaminating these cells could involve a significant effort, but would nonetheless have to be completed sometime prior to decommissioning of the facility. Eliminating this hazard from 235-F now would enhance the future safety of the facility.

Externally Generated Hazards. The hazard analysis performed by the site for externally generated hazards was adequate. The facility's structure, limited over-flights, and remote location, in conjunction with maintaining a viable site-wide emergency response capability, provide adequate controls for such hazards.

Fire Hazards. Only a small portion of the facility (mainly the storage vaults) is covered by a fire detection and alarm system. There is no fire suppression system in the facility. Many areas of the facility that are not covered by a fire detection and alarm system also lack an audible alarm annunciation system.

During a walkdown of the facility, a significant amount of combustible material (such as contaminated HEPA filters, plastic boxes, and cables) was found in a room adjacent to one of the material storage vaults. This material was subsequently removed, but continued vigilance will be needed to reduce or eliminate unnecessary transient combustible materials in the facility.

To provide adequate safety for an extended storage mission, DOE should:

- ! Provide automatic fire suppression and fire alarm systems; as an alternative, provide an automatic fire detection and alarm system together with enhanced manual firefighting capability.

- ! With regard to DOE Order 420.1A, determine if the mission is considered “vital,” and establish an unacceptable program interruption time.

Explosions. The hazard analysis performed by the site for explosion hazards was adequate. There are no postulated explosions that could lead to a release of material.

Direct Radiation Exposure. The hazard analysis performed by the site for direct radiation exposure hazards was adequate. The site must maintain a viable radiation protection program in conjunction with its worker protection program to ensure adequate protection for these hazards.

The site does not appear to have thoroughly addressed potential radiation exposure hazards from high-radiation materials expected to be shipped from other sites—in particular material from Hanford. A significant quantity of the Hanford plutonium is reactor-grade plutonium which has an associated high radiation dose rate. The site’s radiation protection experts should conduct an ALARA review to determine appropriate safety measures for handling and storage of these types of high-radiation materials.

Nuclear Criticality. The Board has previously concluded that the site’s criticality safety program is adequate. The nuclear incident monitors (also known as the criticality alarm system) have been removed. An updated criticality safety evaluation is needed to support extended storage and the planned stabilization and packaging process. Reinstallation of the nuclear incident monitors may be required. Other criticality controls typically required for storage and limited processing activities should not be onerous or difficult to implement.

Worker Protection and Maintenance Programs. The worker protection program is considered adequate. The maintenance program is also adequate and a mature program as discussed in section A.3.

At the same time, several maintenance-related measures were identified which could improve reliability and safety for future operations.²⁹

- ! The electrical distribution systems in 235-F were installed in accordance with the 1950s version of the NEC. Assessments are performed routinely for the commercial nuclear industry by NEC-qualified inspectors and have been performed for other facilities at SRS to evaluate electrical systems for compliance with the current NEC. It would be beneficial to assess the existing electrical system for 235-F against current code requirements to identify potential hazards and understand latent system vulnerabilities.

- ! To ensure reliable operation, IEEE STD 242, *Recommended Practice for Protection and Coordination of Industrial and Commercial Power Systems*, recommends that electrical

²⁹ The Board has transmitted these concerns to DOE. Ref. 6.

protective devices be maintained and calibrated in accordance with manufacturers' recommendations. SRS should ensure that the devices in 235-F are subjected to this maintenance practice.

- ! The majority of the electrical cables in 235-F are approximately 50 years old and have exceeded their estimated design life. When cable jackets and insulating materials age, they become brittle and may crack. Monitoring of the condition of such cables is an essential part of effective preventive maintenance by detecting and replacing damaged and deteriorating power and instrumentation and control cables prior to failure.

A.1.4 FB-Line

Safety Basis. The safety basis for FB-Line activities is documented in a draft Safety Analysis Report claimed by DOE to comply with 10 CFR Part 830. This document, however, has the same weakness discussed above for the safety basis for 235-F—namely, that the hazard analysis does not identify the specific controls needed to protect workers. The fact that the facility has a short life expectancy and is expected to be deactivated, de-inventoried, and decommissioned by July 2005 was used to justify exemptions from DOE requirements and a decision not to make any significant safety modifications. For example, the entire fire detection and alarm system was deactivated because significant modifications would have been needed to meet applicable standards and reach an acceptable operating condition. Since some processing activities are continuing in the facility, DOE has chosen to maintain (and designate as safety equipment) the nuclear incident monitors to protect the workers from the consequences of a criticality accident.

The safety of operations in FB-Line relies on the availability of several features of F-Canyon. For example, the F-Canyon exhaust system is an active safety-class control that is relied upon to provide confinement of fire-generated releases in FB-Line. Similarly, the safety-class electrical distribution system of F-Canyon is relied upon to provide the necessary power supply to the ventilation fans in FB-Line, designated as safety-significant in this facility's safety basis. This dependency of FB-Line on F-Canyon does not appear to be a problem since both facilities' missions are clearly defined for the next few years.

Natural Phenomena Hazards. The hazard analysis performed by the site for natural phenomena hazards was adequate. This conclusion was reached in large part because of the short remaining life of the facility. Furthermore, the majority of dispersible material-at-risk has been removed, and the remaining materials are planned to be removed in the next few years. Although the facility structure was not specifically evaluated as part of this review, previous reviews of F-Canyon and FB-Line have shown them to be robust structures.

Loss of Containment/Confinement. The existing safety basis for the FB-Line credits the F-Canyon ventilation exhaust system for mitigating the consequences of releases of radioactive material from the facility. This system is expected to direct the accidental release of radioactive materials through F-Canyon's sand filters, resulting in inconsequential effects on the public. Several safety-class ventilation exhaust components are

located on the same instrument panel in the fan house and share the same sensing line. A single event could cause redundant switches to fail. This configuration does not meet current single-failure design criteria for safety-class components.

The cables from the safety-class pressure switches to the fans and control room are considered process support. There is also a manometer located near the pressure switches that shares the same pressure sensing line, but it is not safety-related. The F-Canyon ventilation system, and by extension the FB-Line ventilation system, are not compliant with the single-failure criteria of IEEE STD 379, *Application of the Single-Failure Criterion to Nuclear Power Generating Station Safety Systems*, and the separation criteria of IEEE STD 384, *Criteria for Independence of Class 1E Equipment and Circuits*.

Given the facility's age and relatively short remaining life, it would be impractical to upgrade these systems in FB-Line to meet current standards. If additional missions are assigned to FB-Line, however, corrective actions will be required to reduce single-failure vulnerabilities. At a minimum, the monitoring of the non-safety-related manometer should be elevated to a TSR, thus providing some additional assurance that the F-Canyon sand filter will operate as designed.

Externally Generated Hazards. The hazard analyses performed by the site for externally generated hazards was adequate. The facility's structure, limited over-flights, and remote location, in conjunction with maintaining a viable site-wide emergency response capability, provide adequate control for such hazards.

Fire Hazards. The facility does not have a fire detection and alarm system or a fire suppression system. This lack of any fire detection, automatic suppression, or alarms renders the facility vulnerable to incipient fires growing into a facility fire and engulfing hazardous materials. The facility relies on administrative controls to minimize the size of a potential fire through limitations on combustible loading, and on the control of ignition sources to reduce the probability of a fire. The facility has been granted exemptions from fire protection features typically required in such facilities, based in large part on the short remaining mission of the facility.

The administrative controls did not appear to be effective and need to be strengthened. For example, during a walkdown, the Board's staff noted an area containing combustibles in excess of the limit of the combustible control procedure. This limit can be exceeded temporarily (such as during staging of waste bags for removal from the building that day) provided the excess material is under the control of a responsible party; however, management could not identify the party responsible for controlling excess material in this temporary holding area. The administrative controls used to compensate for the lack of a fire detection and alarm system also may be ineffective in ensuring that personnel evacuate the building in the event of a fire. Administrative controls in FB-Line require workers entering rooms that lack coverage by a Public Address (PA) system to log in with the facility operations office. In theory, if a fire were detected, the shift manager would send someone to alert the workers to evacuate. While interviewing a shift manager in FB-Line, however, it became

clear that the abnormal operations procedure included no step to notify workers in areas where the PA system cannot be heard until an accountability check has identified a missing worker.

Another deficiency exists: in one of the stairwells in FB-Line, the power, instrumentation, and control cables routed through the cable trays are coated with a protective material (Flammastik) to prevent the initiation and rapid propagation of fire. Such protective coatings may reduce the heat transfer characteristics associated with the ampacities codified in industry standards. Hence, ampacity testing is necessary to determine whether the coating has affected the rating of fire-protected cable systems. IEEE STD 848-1996, *Procedure for the Determination of the Ampacity Derating of Fire-Protected Cables*, should be used to evaluate the adequacy of the coated cables in the stairwell, as well as in other locations where such coated cables exist.

Explosions. The hazard analysis performed by the site for explosion hazards was adequate. There are no postulated explosions that could lead to a release of material.

Direct Radiation Exposure. The hazard analysis performed by the site for direct radiation exposure hazards was adequate. The site must maintain a viable radiation protection program in conjunction with its worker protection program to ensure adequate protection from these hazards.

Nuclear Criticality. The Board has previously concluded that the site's criticality safety program is adequate. The hazard analyses performed by the site for criticality events were adequate. The criticality controls associated with stabilization and packaging processes was validated during the required operational readiness assessment for these activities.

Worker Protection and Maintenance Programs. The worker protection program is considered adequate. The maintenance program is also adequate and a mature program as discussed in section A.3.

A.2. ADEQUACY OF PROVISIONS FOR REMOTE MONITORING AND FOR HANDLING

Congress directed the Board to evaluate the adequacy of provisions made by DOE for remote monitoring and for handling of the stored material. DOE has made no provision for remote monitoring of the material for safety purposes. Remote monitoring for safeguards purposes, including installation of cameras and the use of electronic tamper indicating devices, has been provided. Such safeguards monitoring warns of removal of or tampering with storage packages but does not provide any information on the condition of the material. Although no provisions for remote monitoring have been made, SRS intends to monitor for aging and unusual conditions within the packages through a routine container inspection program.

Routine inspections of the containers will be conducted in either FB-Line or 235-F. Accordingly, containers in KAMS must be moved to one of these facilities for these inspections. According to current plans, routine inspections and monitoring of containers will begin in fiscal year 2005, around the time the

capability to perform these activities would be added to 235-F. FB-Line can easily be prepared to receive containers for routine activities; given the timing, however, it is doubtful that any routine inspections or monitoring would actually be accomplished in FB-Line. Building 235-F can also be prepared to receive containers from KAMS, but DOE has not yet undertaken this task.

Handling of material for retrieval from either KAMS or 235-F should not present a significant safety problem. The plutonium will have been stabilized and packaged into robust DOE-STD-3013 containers that facilitate handling and retrieval. Material stored in 235-F can easily be placed into shipping containers for retrieval and shipment. Material stored in KAMS will already be in a shipping container or similar container such as a pipe overpack container; this will allow ready shipment to a disposition facility.

Other than being moved to a disposition facility, the material will generally not be moved from KAMS except as needed to repair a damaged container and to conduct routine inspections and monitoring. The KAMS plan for handling, moving, and accepting a damaged, potentially contaminated container for further disposition was not well integrated with the receiving facility—FB-Line for the next several years. The procedures for moving a contaminated container from KAMS had not been prepared and validated. KAMS facility personnel indicated that such a container would likely be bagged to control any contamination. FB-Line personnel indicated they would not accept a bagged container. FB-Line would expect a damaged container to be packed into a larger, intact container for transport. The procedure at FB-Line for accepting a container includes limits that would exclude the quantity of material typically in a DOE-STD-3013 container. FB-Line has a permanent decontamination structure with a filtered ventilation system for processing and repackaging of contaminated containers. However, this area was not set up to handle an overpacked shipping container. These deficiencies need to be resolved, and procedures for dealing with a damaged container need to be developed and validated.

A.3 ADEQUACY OF STORAGE AFTER 2019

Once the existing SRS facilities have been made adequate and thus can be expected to safely perform storage and processing missions, use of the facilities beyond 2019 becomes a problem in management of the facility's aging. SRS has established a three-pronged approach for managing facility aging:

- ! Proactive application of maintenance (preventive, predictive, and corrective)
- ! Compliance with site maintenance procedures
- ! Implementation of a site-wide training and qualification program for maintenance

The SRS maintenance program is mature, and an effort is being made to further improve the program by employing reliability-centered maintenance principles to enhance equipment availability. The preventive

maintenance program appears to be effective as there was little or no backlog of maintenance for safety-related equipment. The site employs an aggressive predictive maintenance program, which includes vibration analysis for rotating equipment, infrared thermography, ultrasound measurements, and lubrication analysis. More than 8,000 components are monitored under the program. The corrective maintenance program also appears to be effective, and the backlog of work appeared to be normal for these types of facilities. It should be expected that maintenance costs for these facilities will increase as the facilities continue to age.

APPENDIX B

TEXT OF ORIGINAL REPORTS BY THE BOARD'S STAFF

This appendix presents the text from the reports completed by the Board's staff to document the results of onsite reviews performed to support the Board's study. The information in these reports has been shared with DOE-SR and more immediate safety issues were presented to DOE.

B.1 STRUCTURE

B.1.1 KAMS

KAMS is a robust and massive reinforced-concrete structure that is embedded 40 feet underground. The MSA encompasses the old Process, Crane Wash, Crane Maintenance, and Stack Areas. It consists of two structurally independent structures: the Process Building (Process, Crane Wash, and Crane Maintenance) is separated from the Stack Building and the adjacent buildings by expansion joints. Expansion joints allow independent movement and would minimize the interaction of structures during a seismic event. All material storage is located at ground level.

General Structural. The analysis of record, referred to as the KAMS evaluation, was completed in 1999. The structures and components that compose the storage area are classified as PC-3. Adjacent structures or equipment with less stringent performance criteria could impact and adversely affect the performance of the storage areas during a seismic event. Structures and components that pose this risk have been identified and have been analyzed to PC-3 criteria. For example, an adjacent building housing the exhaust fans is qualified for PC-2 but was evaluated to PC-3 criteria to address seismic interaction concerns. Also, equipment inside the MSA that does not meet PC-3 criteria has been removed.

Seismic Response. The KAMS structures were evaluated in the 1989–1992 time frame to support the K-Reactor Restart Program. The current analyses are based on the structural models developed in the restart program. The soil-structure interaction (SSI) model was expanded to include three-dimensional mass eccentricities and extends the model down to elevation -40 feet, where the structure is supported by soil. The model is subjected to seismic motion at -40 feet represented by time histories compatible with the PC-3 design spectrum. The results have been verified by performing additional analyses using different software. In addition, the structure-to-structure interactions through the soil medium have been evaluated and shown to only influence adjoining buildings locally.

Using the demands produced by the SSI model, Westinghouse Savannah River Company (WSRC) evaluated the adequacy of the structural elements by comparing them to member capacities. Acceptance criteria are consistent with codes and standards such as the ACI 349-85, *Code Requirements for Nuclear Safety Related Concrete Structures*; and DOE-STD-1020, *Natural Phenomena Hazards Design and*

Evaluation Criteria for Department of Energy Facilities. WSRC has concluded that the structural components supporting the stored material are acceptable.

Ground Motion Response Spectra. In the late 1990's, the Board's staff discussed the adequacy of the site's design response spectrum with both DOE and WSRC. SRS agreed to incorporate higher margins of seismic safety in new facilities categorized as moderate or high hazard. In part, this agreement consisted of enhancing the existing PC-3 ground motion spectrum and applying a 1.2 load factor to the seismic load component of the structural load combination. However, at the time of the KAMS analysis, this agreement had not been reached. As such, the current KAMS analysis does not use the enhanced PC-3 spectrum or the 1.2 load factor. WSRC understood the new approach applied only to new facilities. The staff believes the agreed upon approach should be extended to existing facilities such as KAMS which have been given a new, extended mission.

Although detailed calculations were not performed, WSRC informally communicated that KAMS would most likely be found to be adequate if the enhanced PC-3 spectrum and load factor were used. Though not verified through formal calculations, the staff believes the KAMS building structures would satisfy the enhanced criteria. The K-Reactor Restart Program evaluation used the United States Nuclear Regulatory Commission Regulatory Guide 1.60 spectrum normalized to 0.20 g peak ground acceleration as the basis for acceptance in 1989. This Regulatory Guide 1.60 spectrum envelopes the enhanced PC-3 spectrum by a significant margin.

Dynamic Soil Properties. Some differences in the soil shear wave velocities assigned to the subsurface soils were noted between the earlier and current analyses. With the exception of the very top layer, the shear wave velocities of the respective soil layers are comparable. The staff believes that the shear wave velocity of the top layer in the KAMS analysis is unrealistically high and its influence on the site response analysis needs to be better understood. The current KAMS analysis and the 1989 analysis utilize an average shear wave velocity of the top soil layer of 4190 feet per second and 4843 feet per second, respectively.

Material Properties of Reinforced Concrete. The K-Reactor restart evaluation was based on the ultimate strength approach of ACI 349-85 utilizing a concrete strength of 2500 pounds per square inch (psi) and a rebar yield stress of 40,000 psi. The KAMS analysis adopts these capacities and recalculates the demand to capacity (D/C) ratios for only those components that exhibit a larger seismic demand than that predicted in the 1989 analysis. All D/C ratios are reported to be well below 1.0 with calculated safety factors in excess of 7.0.

KAMS Structures—Conclusion. Based on the above review, the team concludes that the KAMS analysis adequately documents the acceptability of the existing structures to store nuclear material in a PC-3 facility, subject to the caveat discussed above regarding the seismic design response spectrum. The seismic evaluation uses standard analytical models and methods of analysis. The seismic response in the KAMS evaluation is generally lower than the seismic response published in the K-Reactor Restart Report, resulting in lower seismic demands. Based on the calculated D/C ratios, the material can be safely stored in the MSA.

B.1.2 Building 235-F

Building 235-F is a reinforced concrete structure built in the early 1950s. It is approximately 222 feet long, 109 feet wide, and 28 feet high. The exterior walls of the two-story structure are 14 inches thick. The floor slabs are 8 inches thick, with the first floor being a slab on grade. A reinforced-concrete ventilation duct that is 14 inches thick was added in 1973–1974 as part of the PuFF installation. The duct is anchored to the roof slab and extends the length of the roof and down along the west wall of the building.

General Structural. The analyses of record for 235-F are out-dated, lacking both the rigor and the acceptance criteria that would be required today. For example, the acceptance of structural elements is based on the 1971 edition of ACI 318, *Building Code Requirements for Structural Concrete*. Also, the seismic analyses were based on Housner spectra that are less conservative than the current DOE requirements contained in DOE-STD-1020-2002. If DOE proceeds with plans to utilize 235-F for extended storage and support activities, the staff believes the facility would require a full re-evaluation of the structure.

Ground Motion Response Spectra. As discussed above, the staff believes that the enhanced PC-3 response spectra is appropriate for any new evaluation of Building 235-F. The new extended storage mission warrants the equivalent safety of a new facility.

Soft Zones. Two soil soft zones were encountered during the subsurface exploratory work, one being 4 feet thick and the other 6.5 feet. Both soft zones were discovered in the same testing location, at depths of approximately 122 feet and 150 feet below the ground surface, on the southwest side of the building. WSRC is unable to fully characterize the extent and properties of the soft zone due to the limited amount of exploration in the immediate vicinity of the building. Soft zones can lead to large differential settlements, and the settlement calculations of record do not consider the soft zones. WSRC indicated that it will determine an approach to characterize and assess the potential hazards resulting from the soft zones during the conceptual design stage of the 235-F storage project.

Building 235-F Conclusion. A structural evaluation of the building needs to be completed to current standards before the team can comment on the adequacy of the structure to store and potentially repackaged nuclear material. The potential hazards associated with the soft zones discovered beneath the building could be of sufficient magnitude to cause the building to be inadequate for the proposed mission. WSRC and the Board's staff agree that additional work needs to be performed in order to accurately assess the associated hazards.

B.2 VENTILATION SYSTEMS

B.2.1 KAMS

The ventilation system for KAMS utilizes the original airborne activity confinement system used during K-reactor operation. The HEPA filters in this confinement system have been removed. The facility

therefore relies on material and Type B shipping containers to provide containment of plutonium materials stored in KAMS. The tradeoff with the current system is that the filtered exhaust system is replaced with thousands of Type B shipping containers.

By using the primary exhaust fans and locking the flow dampers, air circulates through the stack, crane maintenance, and process room areas, which constitute the MSA where plutonium is stored in KAMS. The major components of the ventilation system are original equipment and are approximately 50 years old. Much of the system has been deactivated and disabled. Only two out of three primary exhaust fans and dampers are in service. Other supply and exhaust fans have been chained, or had drive belts or motors removed, and associated dampers have been pinned in an open position. Exhaust fans for some below grade areas not associated with the MSA are still active but rarely used. SRS plans to deactivate these fans and associated dampers in the near future. Also, supply fans remain active in the facility's Central Control Room and Purification Area. These areas are not utilized for plutonium storage.

There are two installed filter housings without HEPA filters through which exhaust air passes before entering the exhaust stack. The KAMS ventilation exhaust can accommodate four additional filter housings. Three unused filter housings are currently stored behind K-reactor. K-reactor has contamination in the disassembly and purification areas, independent of the MSA. Given the unused housings and the contaminated areas, the staff believes it would be prudent to install additional housings with HEPA filters and the original stainless steel mesh demisters so that an optional filtered exhaust pathway is available should one be needed.

A minimum air flow rate of 12,000 cubic feet per minute (CFM) through the MSA is required by the safety basis to help protect the shipping containers during a postulated fire. To accomplish this, the stack area roll door, where material enters KAMS, will be fixed open at a height of 140 inches from the dock floor. With the roll door open, the contractor measured flow rates between 17,600 and 24,000 CFM through the facility. The staff noted that temperature extremes during winter and summer or adverse weather conditions (e.g., hurricane, tornado) may affect the habitability of the MSA. The contractor had no additional plans to cope with the changing ambient conditions.

The facility has no plans to replace any major ventilation components, and will rely on their maintenance program to ensure equipment reliability. The components most susceptible to wear and failure are the primary exhaust fans and associated drive motors. There is an inactive, redundant exhaust fan which will facilitate repair and maintenance on the primary exhaust fans if needed.

B.2.2 Building 235-F

The 235-F ventilation system consists of eight supply and five exhaust fan systems. Several fan and exhaust systems have a redundant supply or exhaust fan in standby. Supply systems pull outside air into the facility. Clean areas exhaust directly to the atmosphere through roof registers on top of the building, while radiological controlled areas, including Special Nuclear Material (SNM) storage, exhaust through a safety-

class sand filter and the stack. Radiological controlled areas with process enclosures, like glove boxes, utilize HEPA filters before exhausting through the sand filter and the stack. The sand filter and stack are housed in a separate building, so a safety class concrete exhaust tunnel directs air flow from the 235-F facility to the sand filter and stack house. The exhaust tunnel crosses the facility roof and goes underground adjacent to the facility. In the mid-1980s, the 235-F ventilation exhaust system was separated from the F-Canyon exhaust system. At that time, a new sand filter and new primary and processing exhaust fans were installed.

The staff noted multiple vulnerabilities that could compromise the protection provided by the ventilation system. For example, the pressure switches for three safety-class exhaust tunnel interlocks used to ensure the tunnel and building are not pressurized are grouped together in cabinets. The cabinets are fixed to the same support column. The proximity of the switches make them vulnerable to a common mode failure, like a large piece of equipment striking the cabinets. Simultaneous actuation of all the interlocks could direct the full flow from the primary exhaust tunnel fans through the process enclosure exhaust system in 235-F. The effects of this alignment on the HEPA filters, duct work, and remainder of the ventilation enclosure has not been analyzed. In addition, the separation and redundancy of the safety-class pressure switches would normally be expected. Similarly, the safety-significant interlocks controlling the primary exhaust tunnel fans are grouped together in an outdoor cabinet, where the underground exhaust tunnel meets the sand filter. A single accident could destroy both interlocks, and compromise their safety function.

While the majority of the ventilation system was in good condition, the staff noted some ventilation hardware throughout the facility is in poor condition. Several ventilation grills were capped off or plugged up in the vestibule area and Actinide Billet Line room; it is uncertain if any justification for these modifications exists. Also, construction doors giving access to the safety-class exhaust tunnel on the roof of 235-F are in poor condition.

B.2.3 FB-Line

The ventilation system remains essentially unchanged from its original construction in the 1950s. The primary source of air for the fifth and sixth levels comes from two supply fans located on the sixth level roof (one in standby). The intake duct is routed from the roof to the ground level on the west side of F-Canyon. The active supply fan provides approximately 27,000 CFM of air flow to facility rooms and processes. An additional dry air supply system, also located on the sixth level roof, was recently added for material characterization gloveboxes. Supply air for both the third and fourth levels originates from the F-Canyon center section supply system, which provides approximately 11,000 CFM of air to gloveboxes, facility rooms, and storage areas. Exhaust from all four levels is drawn into the warm canyon tunnel by the F-Canyon primary exhaust fans. These fans are located in the F-Canyon fan house. The air is then filtered by two parallel sand filters before being exhausted through the stack.

The staff noted several items that indicate poor configuration management of ventilation systems. For example, an air vent in a health physicist control station was crudely taped off with cardboard and

masking tape. Proper ventilation balancing is needed to ensure contamination is not spread to clean areas. Several large openings around the doorway between the control station and the adjacent room containing material characterization gloveboxes provide a direct pathway for airborne contamination to travel if this balancing is not maintained. Multiple gauges providing differential pressure measurements between process rooms appeared to be out-of-calibration. Facility engineers were unable to determine if the calibration stickers, which indicated gauges were to be re-calibrated in 2002, were either incorrect or no longer required.

Additional concerns relate to the safety classification and testing of ventilation hardware. Facility gloveboxes, ventilation duct work, and fan and filter housings are classified as safety significant for worker protection during regular operations and accident situations, but facility engineers could not provide any analysis or describe testing procedures that validate the integrity of these components during normal conditions or postulated accidents. For example, no analysis or testing exists that proves the leak tightness of a pressurized glovebox and its exhaust ventilation system during a glovebox fire. Furthermore, the internal components of the ventilation system, including fans and HEPA filters, are not classified as safety-related. The interlocks responsible for maintaining negative pressure in contaminated enclosures during accident conditions are also not classified as safety-related. While annual testing is performed for the majority of these interlocks, the staff noted that hardware ultimately responsible for controlling the safety response of the system during accident situations would typically have a more stringent safety classification.

A final staff concern with FB-Line ventilation relates to the older of two sand filters in the F-Canyon exhaust ventilation system. FB-Line ventilation ultimately exhausts through F-Canyon's safety class exhaust tunnel and sand filters before entering the canyon stack. F-Canyon engineering has noted an increase in the number of dimples in the filter media in the older sand filter. These dimples indicate a failure of the lateral flow and distribution structure below the sand and crushed rock. The dimple sizes range up to approximately six feet in diameter and three feet in depth. Closure of this filter may be required before decommissioning activities are complete in both F-Canyon and FB-Line.

B.3 FIRE PROTECTION SYSTEMS

B.3.1 General

Use of Administrative Controls in Lieu of Engineered Systems. All three facilities rely on administrative controls in place of engineered fire protection systems. Although no issues with transient combustible controls were noted in KAMS, the transient combustible controls for the other two facilities did not appear to be as effective. For example:

- ! Excessive combustibles were noted in 235-F in areas adjacent to the storage vaults during a facility walk down.

- ! During a walk down of FB-Line, the staff noted an area with combustibles in excess of the combustible control procedure limit. This limit can be temporarily exceeded (such as staging waste bags for removal from the building that day) provided the excess material is under control of the generator; however, management could not identify the party responsible for controlling excess material in this temporary holding area.

The staff has concerns that the administrative controls used to compensate for the lack of fire detection and alarm systems may not be effective in ensuring personnel evacuate the building in the event of a fire. FB-Line and 235-F have administrative controls that require workers entering rooms without PA system coverage to log in with the facility operations office. In theory, if a fire were detected, the shift manager would send someone to alert the workers to evacuate. However, while interviewing the shift manager in FB-Line, it became clear that there was no step in the abnormal operations procedure to notify workers in areas where the PA system cannot be heard until an accountability check identifies a missing worker.

Designation of Vital Facilities. KAMS and 235-F have not been identified as “vital” DOE programs, nor has any “unacceptable program interruption” been established by DOE as required in DOE Order 420.1A. Based on these mission definition parameters, protection measures beyond those identified in the existing FHA and DSA, which do not address temporary loss of KAMS or 235-F, may be required.

Approval of Exemptions and Equivalencies. The DOE Assistant Secretary for Environmental Management has granted the DOE-SR the authority to approve equivalences and exemptions to required fire safety orders, referenced codes, and standards. DOE-SR further delegated this authority to the contractor for approval of equivalences and exemptions for non-nuclear facilities, as well as equivalences for nuclear facilities. According to DOE-SR, this delegation of authority was granted due to lack of sufficient manpower to review the large number of equivalences and exemptions generated at the site. The staff has concerns for the adequacy of the process for determining what deviations are judged as equivalences versus exemptions, the lack of consistent oversight, and the potential for a conflict of interest by the parties associated with the contractor approval process. This process does not appear to be in accordance with the requirements of DOE Order 420.1A, *Facility Safety*.

B.3.2 KAMS

KAMS has no automatic suppression or detection systems, and only a partial fire department standpipe system to facilitate fighting a fire. DOE Order 420.1A would normally require automatic suppression or detection as a defense-in-depth feature of a robust fire protection program. The FHA relies on a single level of protection for the plutonium stored in the shipping containers in the MSA. Fire barriers are the single level of defense to protect the plutonium from a fire outside the MSA. Ventilation in conjunction with administrative controls on the quantity and locations of combustibles compose the single level of defense to protect the plutonium from a fire inside the MSA. Failure of any one of these systems to perform as required could result in a fire that threatens the stored materials.

This single level of protection concept has even been applied to a potential fire in the large number of cables and equipment in the actuator tower above and adjacent to the MSA. The FHA and DSA concluded that the cables can burn uncontrolled (and not threaten the plutonium) provided: (1) a 40-square-foot opening in the roof of the space allows venting of heat and products of combustion, and (2) the fire resistant coating on structural beams in the space performs as designed. Obstruction of the roof vent or failure of the fire resistant coating to perform as desired could allow a cable fire to threaten the stored materials.

The fire thermal analysis performed in support of the DSA postulates two bounding fire scenarios that determine the safety controls:

- ! The first scenario was a fire at the +48 ft elevation that propagates to the Actuator Tower and into the MSA where plutonium storage packages are stored. This fire scenario is credible due to the significant amount of combustible materials at this elevation (such as old abandoned cables). Because the KAMS plutonium storage mission was expected to be of short duration, DOE decided not to remove the combustibles and thereby eliminate the source of fire; instead a 40-square-foot hole (vent) was cut into the roof of the Actuator Tower to vent heat and gases from the fire. Given the current plans for an extended storage mission, it would have been more appropriate to prevent the potential fire by removing the combustibles.

- ! The second fire scenario was a fire in the MSA resulting from sequential burning of several fork lifts. The thermal analysis, and the DSA, credit one of two 903 fans to be operating during this event. The fan draws air through the MSA to prevent the shipping containers from exceeding their qualified temperatures during the fire. The DSA, however, identified only the 903 fan flow monitors as safety-class equipment to be maintained by TSR-level controls. Additionally, 903 fan suction gauges which provide a safety-significant backup to the flow monitors were not maintained by TSR-level controls. The ventilation system (903 fans and associated flow path) should be identified as safety-class equipment to ensure adequate protection of the public, consistent with DOE and SRS directives.

B.3.3 Building 235-F

Building 235-F has only a partial detection system and no automatic fire suppression systems. Nor does 235-F have a fire department standpipe system to assist in fighting fires. The facility relies on administrative controls to minimize the size of a potential fire through combustible loading limitations, and to reduce the probability of a fire by controlling potential ignition sources. The facilities have been granted exemptions to required fire protection features typically required in such facilities, based in large part on an expected short remaining mission for the facility. Such justification will not be valid for 235-F if it is used for extended plutonium storage.

B.3.4 FB-Line

FB-Line has no automatic suppression and no detection system, and only a partial fire department standpipe system. The facility relies on administrative controls to minimize the size of a potential fire through combustible loading limitations, and to reduce the probability of a fire by controlling potential ignition sources. The facility has been granted exemptions to fire protection features typically required in such facilities, based in large part on the short remaining mission of the facility.

B.4 ELECTRICAL SYSTEMS

B.4.1 KAMS

Electrical Distribution System. In general, the staff found the electrical distribution system to be adequate since the system is currently not credited with any safety function. However, in a letter dated June 12, 2003, the Board noted that the ventilation system for KAMS was not designated as safety-class consistent with DOE requirements to preclude unacceptable off-site consequences during certain accidents. Such a designation would require reclassification of the existing electrical system and significant enhancements to the present emergency power capability.

Electrical Calculations. The short-circuit analysis for KAMS is based on the short-circuit currents from the original electrical calculations for K-Reactor. Because there have been major equipment modifications, including removal of many of the electrical loads, the short-circuit analysis needs to be reevaluated using short-circuit currents based on the existing configuration of the electrical distribution system. Such an evaluation would verify the capability of the electrical equipment to perform safely without initiating a fire or an explosion.

B.4.2 Building 235-F

Lightning Protection System. The current lightning protection system is intended to provide protection via the partial Faraday cage that is established by the building's interconnected structural steel rebar. However, the existing arrangement is rendered ineffective by unbonded metallic penetrations that breach the cage boundary. By attaching to an unbonded rooftop or high-elevation penetration, lightning energy (capable of igniting in-situ combustibles) could couple directly into the facility, bypassing the rebar cage altogether. Given the lack of viable fire suppression capabilities in 235-F, it would be prudent to install a lightning protection system compliant with NFPA Standard 780, *Standard for the Installation of Lightning Protection System*.

NEC-Type Assessments. The electrical distribution system in 235-F was installed in accordance with the 1957 version of the NEC. Facility personnel were unaware of any assessments performed in recent years to ensure compliance with either the current NEC or the code of record. Such assessments are performed routinely for the commercial nuclear industry by NEC-qualified inspectors and have been

performed for other facilities at SRS to evaluate electrical systems for compliance with the NEC. The staff believes it would be beneficial to assess the existing electrical system for 235-F against current code requirements to identify potential fire hazards and understand latent system vulnerabilities.

Calibration of Protective Devices. To ensure reliable operation, IEEE STD 242-2001, *IEEE Recommended Practice for Protection and Coordination of Industrial and Commercial Power Systems*, recommends that electrical protective devices be maintained and calibrated in accordance with manufacturer's recommendations. The 235-F circuit breakers and relays are maintained on a 5-year calibration frequency. Representatives of 235-F could not verify whether this calibration frequency is consistent with the manufacturer's recommendation. The Board's staff believes the calibration tests on the breakers and relays should be in accordance with the manufacturer's recommendation to ensure that the equipment will operate as designed.

Electrical Cables. The majority of the electrical cables in 235-F are approximately 50 years old and have exceeded their estimated design life. Power, instrumentation, and control cables can deteriorate during service. When cable jackets and insulating materials age, they become brittle and may crack. Because a number of facility safety systems rely on the working condition of these cables, continued monitoring of their condition is an essential part of effective preventive maintenance. Such monitoring of the condition of the cables improves the service life and reliability of electrical equipment by detecting damaged and deteriorating power and instrumentation and control cables prior to equipment failure.

Several techniques for this type of monitoring exist; for example, the Defense Waste Processing Facility at SRS uses an Electronic Characterization and Diagnostics (ECAD) system for monitoring the condition of cables. The types of degradation and problems that can be detected by the ECAD system are changes to dielectric materials, deterioration of circuit insulation, high-resistance connections, short circuits, open circuits, moisture intrusion, circuit noise, and development of conducting paths. The condition of safety-related cables needs to be determined using a suitable system for monitoring the condition of the cables to support an extended storage mission in this building.

B.4.3 FB-Line

Ampacity Derating of Fire-Protected Cables. In one of the stairwells, the power, instrumentation, and control cables routed through the cable trays are coated with a protective material (Flammastik) to prevent the initiation and rapid propagation of fire. Such protective coatings may reduce the heat transfer characteristics associated with the ampacities codified in industry standards. Hence, ampacity testing to determine whether the coating has affected the rating of fire-protected cable systems is necessary. The Board's staff believes IEEE STD 848-1996, *IEEE Standard Procedure for the Determination of the Ampacity Derating of Fire-Protected Cables*, should be used to evaluate the adequacy of the coated cables in the stairwell, as well as in other locations where such coated cables exist.

NEC-Type Assessments. As discussed above for Building 235-F, it would be beneficial to assess the existing electrical system against current code requirements to identify potential fire hazards and understand latent system vulnerabilities.

B.5 INSTRUMENTATION AND CONTROL SYSTEMS

As part of this task, the Board's staff reviewed the adequacy of instrumentation and control (I&C) systems for KAMS, Building 235-F, and FB-Line at SRS. The staff's review revealed that none of the I&C systems for the ventilation systems for these facilities comply fully with the industry standards for safety-class systems noted in DOE Guide 420.1-1, *Nonreactor Nuclear Safety Design Criteria and Explosives Safety Criteria Guide for use with DOE O 420.1, Facility Safety*. Although this situation may be acceptable for short-term missions in FB-Line, the staff does not consider it acceptable for extended missions in existing facilities.

B.5.1 KAMS

In a letter to DOE dated June 12, 2003, the Board noted that not designating the KAMS ventilation system as safety-class was inconsistent with DOE requirements. If the ventilation system were designated safety-class, the flow instruments probably would not be required. However, the current safety basis requires safety-class ventilation system flow instruments and a safety-significant exhaust fan inlet plenum pressure gauge. There are no control room or local audible alarms associated with these instruments. The TSRs require verifying adequate ventilation flow every 18 hours. The contractor plans to use these new flow instruments to fulfill this TSR requirement. The contractor stated that the safety-significant/safety-class designations were not required based on site engineering procedures. However, the contractor chose to identify these instruments as safety systems in the safety basis to increase confidence in the systems, and DOE approved the designation.

Flow Instruments. DOE Guide 420.1-1 identifies IEEE STD 379 and IEEE STD 384 as consensus standards for safety-class components. The ventilation flow instruments do not comply with either of these standards. The flow sensors and connections to the flow analyzers are located within inches of each other, so both could easily be rendered inoperable by a single event. Both flow analyzers obtain power from the same non-safety power source, not diverse safety-class power supplies. Therefore, the reliability of neither instrument is assured.

A waiver for the single-failure and separation criteria in IEEE STD 379 and 384 was approved by contractor management in 2002. The basis for approving the waiver was that the contractor's *Conduct of Engineering (E7) Manual* procedure 2.25, *Functional Classification*, did not require the equipment to be safety-class because it would be used only to monitor initial conditions for fire accident scenarios. Such justification is inadequate since the DOE-approved authorization basis requires the equipment to be safety-class.

These flow instruments were procured as commercial-grade and subsequently qualified for safety-class application using the site's commercial grade item dedication process. The staff considered the evaluation for these flow instruments inadequate for the following reasons:

- ! The flow analyzer and indicator are microprocessor-based. In all other applications known to the vendor, these instruments are used only as temporary measurement and test equipment. Although the vendor did not identify any problems with continuous use, it is unclear how the flow instrument components, particularly the microprocessor-based components, will perform when used continuously as installed process measuring equipment. This issue was not addressed by the site.
- ! The evaluation did not address equipment availability or reliability—key characteristics of safety-class instruments.
- ! The functional test of the installed equipment had no acceptance criteria. The two instruments were located only inches apart, yet the readings were significantly different. There was no justification for this difference.

The TSRs do not have a surveillance requirement to calibrate this equipment periodically, as is normally the case for safety-class instrumentation. There is a TSR surveillance requirement to perform a biannual instrument loop check. This would be a qualitative verification of acceptable performance, and in other applications is typically done with another independent instrument. The contractor stated that the loop check for the flow instruments would be performed by removing them and testing them in a wind tunnel. However, testing in a wind tunnel is not specified in the TSR surveillance requirement. Furthermore, such a test would not be a true calibration traceable to national standards. A TSR surveillance requirement for periodic calibration of the ventilation flow loop ought to be implemented.

Based on the considerations discussed below, the staff believes that the calibration needs to be performed more frequently than every 2 years:

- ! The contractor stated that the flow analyzers perform periodic automatic self-checking but do not recalibrate themselves. However, the staff subsequently noted that the vendor's operating instructions state: "Internal calibration and zeroing of the AirData Multimeter are fully automatic." It is unclear to the staff that this automatic recalibration will perform properly if the device is run continuously for the currently planned 2-year period between instrument loop checks.
- ! The vendor suggests returning the instruments to the vendor every 2 years for calibration and software updates. Given the lack of experience with continuous operation of these instruments, it would appear prudent to send the equipment back to the vendor for calibration more frequently until the instruments' performance is better understood.

Additionally, controls for the software configuration must be established to ensure that changes made by the vendor do not adversely impact the operation of the instruments at KAMS.

- ! The staff also believes it would be appropriate to trend the flow instrument readings to identify divergence from expected values, thus helping to assess how these instruments perform in continuous operation. Given that the two instruments are providing significantly different readings, simply comparing the two indications will not be useful.

Exhaust Fan Inlet Plenum Pressure. The exhaust fan inlet plenum pressure gauge is a safety-significant backup for the safety-class flow instruments. There is no TSR surveillance requirement for routine monitoring of this gauge. Rather, it is required by the TSR to be monitored only when the flow instrument indicates inadequate flow. The contractor monitors the pressure daily during routine rounds, but this is not a TSR action. Additionally, there is no surveillance requirement to calibrate the pressure gauge. The failure to have TSR surveillance requirements for the exhaust fan inlet plenum pressure negates the defense-in-depth benefits of having safety-significant backup equipment for the safety-class flow indicators.

B.5.2 Building 235-F

Building 235-F currently has safety-class ventilation exhaust tunnel interlocks to prevent release of legacy radioactive material to the environment. There are also safety-significant interlocks to start the standby filter exhaust fans. These instruments were designed to older Dupont standards that permitted the use of non-safety wiring for safety instruments if the controlled component failed in the safe condition on loss of signal or power. IEEE STD 384 prohibits this practice because electrical short circuits involving the non-safety wiring could prevent safety actions. Additionally, the instruments do not meet single-failure and separation criteria for safety-related equipment. They use the same sensing line and are in close proximity to each other. If the Building 235-F safety analysis for extended storage and related activities requires safety-class exhaust tunnel interlocks, the associated controls need to be upgraded to be consistent with DOE guidance.

B.5.3 FB-Line

The existing safety basis for the FB-Line credits the F-Canyon ventilation exhaust system for mitigating the consequences of releases of radioactive material from the facility. The existing safety basis for F-Canyon identifies several ventilation exhaust components as safety-class. These components are located on the same instrument panel in the fan house and share the same sensing line. A single event could cause redundant switches to fail. This configuration does not meet current single-failure design criteria for safety-class components.

The cables from the safety-class pressure switches to the fans and control room are considered process support. There is also a manometer located near the pressure switches that shares the same

pressure sensing line, but it is not safety-related. The staff concluded that the F-Canyon ventilation system, and by extension the FB-Line ventilation system, were not compliant with the single-failure criteria of IEEE STD 379 and the separation criteria of IEEE STD 384.

The contractor addressed some of these issues in a backfit analysis, M-BFA-F-00002, *Canyon Exhaust Vacuum Low-Low Alarm and 292-F Instrument Air Receivers Low Pressure Alarm*. Given the facility's age and relatively short remaining life, the staff believes it is impractical to upgrade these systems in FB-Line to meet current standards. However, if additional missions are added to FB-Line, corrective actions will need to be taken to reduce single-failure vulnerabilities. At a minimum, the monitoring of the non-safety-related manometer will have to be elevated to a TSR surveillance requirement, thus providing some additional assurance that the F-Canyon sand filter is operating as designed.

B.6 MAINTENANCE AND WORKER PROTECTION MANAGEMENT PROGRAMS

B.6.1 Standards and Requirements

The maintenance programs for KAMS and 235-F are organized to meet established standards and requirements. Core maintenance program requirements are established by DOE in DOE Order 433.1, *Maintenance Management Programs for DOE Facilities*, and DOE Order 430.1A, *Life Cycle Management*. These maintenance requirements are delineated in SRS Standards/Requirements Identification Documents (S/RIDs) which, in turn, are incorporated into the site operations contract. The SRS contractor, WSRC, implements the S/RIDs through the policies and procedures established in its Procedure Manual 1Y, *Conduct of Maintenance*, the authoritative, working-level document for the conduct of maintenance throughout SRS. Procedure Manual 1Y adequately captures the maintenance requirements of DOE Order 433.1 and DOE Order 430.1A.

B.6.2 DOE Oversight

Maintenance oversight occurs at several levels and focuses on ensuring maintenance requirements are met, ensuring that maintenance is effective and promotes safe operations, and identifying and resolving maintenance issues. Under the current DOE organization and its policies and procedures, oversight efforts are adequate to attain the stated objectives.

Day-to-day oversight of maintenance activities is accomplished by the DOE facility representatives assigned to KAMS and 235-F. The facility representatives observe and assess maintenance efforts to ensure the required elements of a maintenance task (e.g., pre-job brief, identification and control of hazards, field operations, post maintenance testing, etc.) are carried out effectively. In addition to the day-to-day oversight of maintenance, oversight of functional areas that support the maintenance programs such as the systems engineering program is accomplished via a formal assessment. For the most part, any issues arising from the facility representatives' observations are resolved verbally with WSRC management.

Well-defined lines of communication exist to resolve issues and enhance feedback. A daily conference call among the SRS DOE facility representatives serves to facilitate exchanging information and lessons learned. As indicated earlier, direct verbal communications between facility representatives and WSRC management are used to resolve the majority of issues. A quarterly assessment report formalizes assessment findings and is provided to DOE and WSRC senior managers. Serious issues are addressed formally between DOE and WSRC and are tracked to closure.

B.6.3 Maintenance Program

The stated goal of the KAMS and 235-F maintenance programs is to maintain and enhance equipment reliability to support safe and responsible shipping, receiving, storing, and managing of strategic nuclear materials. Attainment of these goals is accomplished through a three pronged approach: proactive application of maintenance (preventive, predictive, and corrective), compliance with the Procedure Manual 1Y, and implementation of a site-wide Maintenance Training and Qualification Program. Standard statistical performance metrics (maintenance backlog, delinquent preventive maintenance actions, etc.) are used to quantify the maintenance efforts. For the most part, maintenance effectiveness is measured anecdotally. The WSRC maintenance program is mature, and effort is being made to employ reliability centered maintenance principles to improve equipment availability. For those systems and equipment at KAMS and 235-F that perform a safety function, the maintenance program appears to provide adequate support to ensure their continued availability.

A recent reorganization of the WSRC maintenance organization has taken place. This reorganization essentially decentralized the maintenance organization and reassigned many maintenance resources to the direct support of facilities. At the time of this review, personnel were still adjusting to the reorganization.

Preventive Maintenance. Data presented during the review indicated that the SRS preventive maintenance program is effective. There were few delinquent preventive maintenance site-wide. Program administration and document processing is facilitated through the use of a computerized maintenance management system (CMMS) which can be accessed by personnel involved in the maintenance program.

Predictive Maintenance. WSRC is employing an aggressive predictive maintenance program. Techniques used in the program include vibration analysis, infrared thermography, ultrasound measurements, and lubrication analysis. In addition, motor current analysis and deflection and modal analyses techniques are available for use in troubleshooting potential problems. More than 8,000 components within the Closure Business Unit are monitored by the predictive maintenance program.

Corrective Maintenance. Approximately 60 percent of all maintenance is corrective with predictive and preventive maintenance accounting for the remainder. Within the total corrective maintenance efforts, approximately one-third is devoted to higher priority, “fix-it-now,” maintenance. The

CMMS mentioned earlier, is used to process corrective maintenance work efforts. The corrective maintenance backlog is acceptable and is normally between 10,000 and 15,000 hours. Routine maintenance, such as relamping, is categorized as “quick-fix” maintenance and is not entered into the CMMS.

B.6.3.1 KAMS

Maintenance plans and history of the safety-class and safety-significant SSCs were reviewed. According to facility personnel, none of these SSCs had ever been operated in a degraded state, and no abnormalities or issues were noted. Predictive maintenance consists of monthly vibration analyses conducted on 17 components, annual thermographic analysis on 10 components, and quarterly oil analyses for four components.

A Structural Assessment Program has been established for KAMS. The program assesses the overall structural condition with particular emphasis on previously detected structural cracks. The program is approximately 10 years old. A structural baseline has been established, and the next full assessment is scheduled for 2005. Crack monitors have been installed at critical areas, and no crack growth has been noted.

A program to monitor and document the status of system aging and any impact it may have on the health of the facility has been initiated recently. This program reports, in detail, the maintainability, reliability, and availability of facility systems via a System Health Report. This report is maintained current by the cognizant system engineer. Presently, one system is briefed weekly to facility management.

B.6.3.2 Building 235-F

Building 235-F is in transition from a shut down condition to a life extension of undefined length. As such, preventive maintenance, predictive maintenance, process instrumentation, availability of spare parts, equipment viability, and functional classification are under review. The status of maintenance plans for safety-class and safety-significant SSCs and recent material problems were reviewed.

Preventive maintenance was on schedule, and corrective maintenance had a 10 job (two week) backlog. Predictive maintenance for 235-F includes monthly vibration monitoring of 39 components and bi-annual thermographic analyses for 255 components. Key elements of the 235-F management of aging equipment include the System Health Report mentioned earlier and System Viability Reports. The latter report will identify equipment ability to meet required life cycle requirements (when known) and also identify deficiencies due to aging.

B.6.4 Work Planning

The SRS work planning process is mature and appears adequate to protect the workers. The site recently implemented an automated hazard analysis program for work planning. This program was originally

created for Hanford and has since been modified for Idaho National Engineering and Environmental Laboratory, and Y-12 National Security Complex. At each of these sites, this process has led to numerous planning problems associated with the failure to adequately integrate the safety professionals with line management and the crafts. Such problems may be worse at SRS because of WSRC's current reliance on the automated work planning software to perform this integration task. In reviewing work packages at SRS, the staff noted that this lack of integration has created problems with de-conflicting controls. Fortunately, it has only resulted in applying redundant controls that decreased operational efficiency, not inadequate or missing safety controls. The staff discussed the weakness in WSRC's approach with DOE.

B.7 MONITORING AND SURVEILLANCE, AND PLUTONIUM ANALYTICAL CAPABILITIES

In support of this study, the Board's staff completed a review of SRS plans for handling damaged packages in KAMS and plutonium analysis capability. Additionally, this review covered the site's plans for monitoring and surveillance required by DOE-STD-3013, *Stabilization, Packaging, and Storage of Plutonium-Bearing Materials*, and to evaluate the extended performance of shipping containers used for plutonium storage in KAMS.

B.7.1 Handling of Damaged Containers

The Board's staff reviewed the process for handling damaged and potentially contaminated shipping containers at KAMS and FB-Line. Currently, KAMS does not have a procedure for handling damaged containers, but facility personnel indicated that they would rely on facility management and radiological control personnel to establish the appropriate response to an event. This response would likely be to double-bag the container to control contamination and ship it to FB-Line for further disposition. If removable contamination was greater than limits for a high contamination area (2,000 disintegrations per minute per 100 square centimeters for plutonium), the ventilation fans would be shut down to minimize the spread of contamination—these fans are required to operate should a fire occur in the MSA.

FB-Line personnel informed the staff that they would not accept a bagged, contaminated container into the facility, and that the container would be required to be overpacked instead. FB-Line has a permanent decontamination structure with a filtered ventilation system for processing and repackaging contaminated containers.

The staff observed that the decontamination structure in FB-Line would likely need to be altered in order for an overpacked container to be easily moved inside the structure. With the existing arrangement in the structure, the overpacked container weighing 400–500 pounds would have to be manually maneuvered around a partition. It was not obvious that the overpacked container would fit through the opening.

The FB-Line procedure for receiving shipping containers limits the amount of plutonium to 4 kilograms. The containers shipped from KAMS could contain up to 4.4 kilograms of plutonium per DOE-STD-3013. This

procedure should be changed to accommodate a bounding fissile mass and address other required data (e.g., moderator ratio).

B.7.2 Container Surveillance Plans

The DOE’s Savannah River Operations Office recently forwarded the plan for surveillance of DOE-STD-3013 containers to the Office of Environment Management for approval. The plan is an integrated plan that considers all the storage sites across the complex. This plan divides the material containers into four groups based on potential failure mechanisms:

- ! Innocuous—primarily plutonium metal and pure plutonium oxide (>80 percent Pu + U)
- ! Pressure generating—primarily impure plutonium oxide (<80 percent Pu + U)
- ! Pressure generating and corrosion—plutonium oxide containing chlorides
- ! Other—material with unusual characteristics as yet undefined

The plan selects containers for nondestructive evaluation (NDE) and/or destructive evaluation (DE) as laid out in the table below. It was not clear how many would be from SRS.

Table B-1 Estimated number of surveillance items*

	FY05	FY06	FY07	FY08	FY09	FY10	FY11	FY12	FY13	FY14	FY15	FY16
Innocuous	2NDE	2NDE	2NDE	2NDE	2NDE							
Pressure	25NDE	25NDE	25NDE 2DE	26NDE 2DE	26NDE 2DE							
Pressure & Corrosion			13NDE 13DE	13NDE 13DE	13NDE 13DE	13NDE 13DE	13NDE 13DE	13NDE 13DE	13NDE 13DE	13NDE 13DE	13NDE 13DE	14NDE 14DE
Other	N/A	N/A	N/A	N/A	N/A	N/A	N/A	N/A	N/A	N/A	N/A	N/A

* from SRS letter SR-NMPD-03-001 dated June 13, 2003.

NDE consists primarily of radiography, leak testing and prompt gamma analysis. DE is primarily a headspace gas sampling and analysis, and a metallographic analysis of the container. The plan states that surveillance of containers from the pressure population will be completed in 5 years since the gas generation rate decreases with time. Since corrosion is a slower phenomenon, surveillance of those items would be completed in 10 years. This plan would be reviewed annually by an Integrated Surveillance Plan Steering Committee to recommend any changes and to support its funding levels.

As the shipping containers used in KAMS are opened, the shipping container materials— primarily o-rings and celotex—would be evaluated for aging degradation. This evaluation was expected to confirm the

shipping containers are acceptable for 10 years without refurbishment (current authorization basis limit) and to support extending the storage period beyond this 10-year period.

In order to comply with DOE-STD-3013, surveillance will need to continue throughout the storage period. The basis for terminating surveillance of containers from the pressure population after 5 years does not consider the minimum pressure (~100 psi) that can be detected in a DOE-STD-3013 container by NDE. Without having established an accurate pressure generation rate, it cannot be determined that pressures would be above the detectable limit during the first 5 years. No justification was provided that supported a position that if a pressure increase was not detected in this period that the containers would then be acceptable for 50 years as required by the standard.

The plan noted that NDE and DE will not be performed at Hanford. Instead containers for surveillance would be preselected and shipped to either Los Alamos National Laboratory or SRS for storage and surveillance. The plan indicated containers would be stored under conditions designed to simulate Hanford storage conditions. If material is not consolidated at SRS, the current plan at Hanford would store the containers in an unventilated underground grout vault. The staff does not believe that the storage conditions in a grout vault at Hanford are understood or established, and therefore, cannot be duplicated at another site.

The grouping of containers into four categories for surveillance is based on the assumption that potential problem containers can be characterized completely according to the principal failure modes. For example, samples from the “pressure & corrosion” category are inspected for internal gas pressure, corrosion, and stress corrosion cracking (SCC). This category potentially includes at least three different mechanisms that could lead to failure. The surveillance plan states that this sampling plan provides a 99.9 percent probability that at least one container from the “worst” 5 percent of containers has been selected for examination. It is not clear how this statistical inference can be valid when the SRS researchers were unable to define what a “worst” case container from this category would look like. The “worst” containers from this category could be those with the highest internal pressures, deepest pit depths, deepest SCC cracks, or some combination of these three measurable characteristics (e.g., pressure plus crack depth). Additionally, preliminary gas generation results from small scale studies at Los Alamos National Laboratory suggest that the kinetics of gas generation from oxides containing the same initial water content may vary depending on impurity levels, such as sodium chloride or magnesium content. This suggests that the current categories may need to be further stratified into homogeneous populations having the same rate controlling mechanisms of failure in order to obtain statistical meaningful data.

B.7.3 Plutonium Analytical Capability

At SRS, the plutonium analyses needed to support storage or to evaluate an abnormal container would be performed in either Building 772 C Laboratory or SRTC. These facilities have adequate analytical capability to perform any needed plutonium analysis or metallographic analysis.

APPENDIX C

TYPICAL STORAGE CONTAINERS

Cross Sectional View of a DOT Type B 9975 Shipping Container*

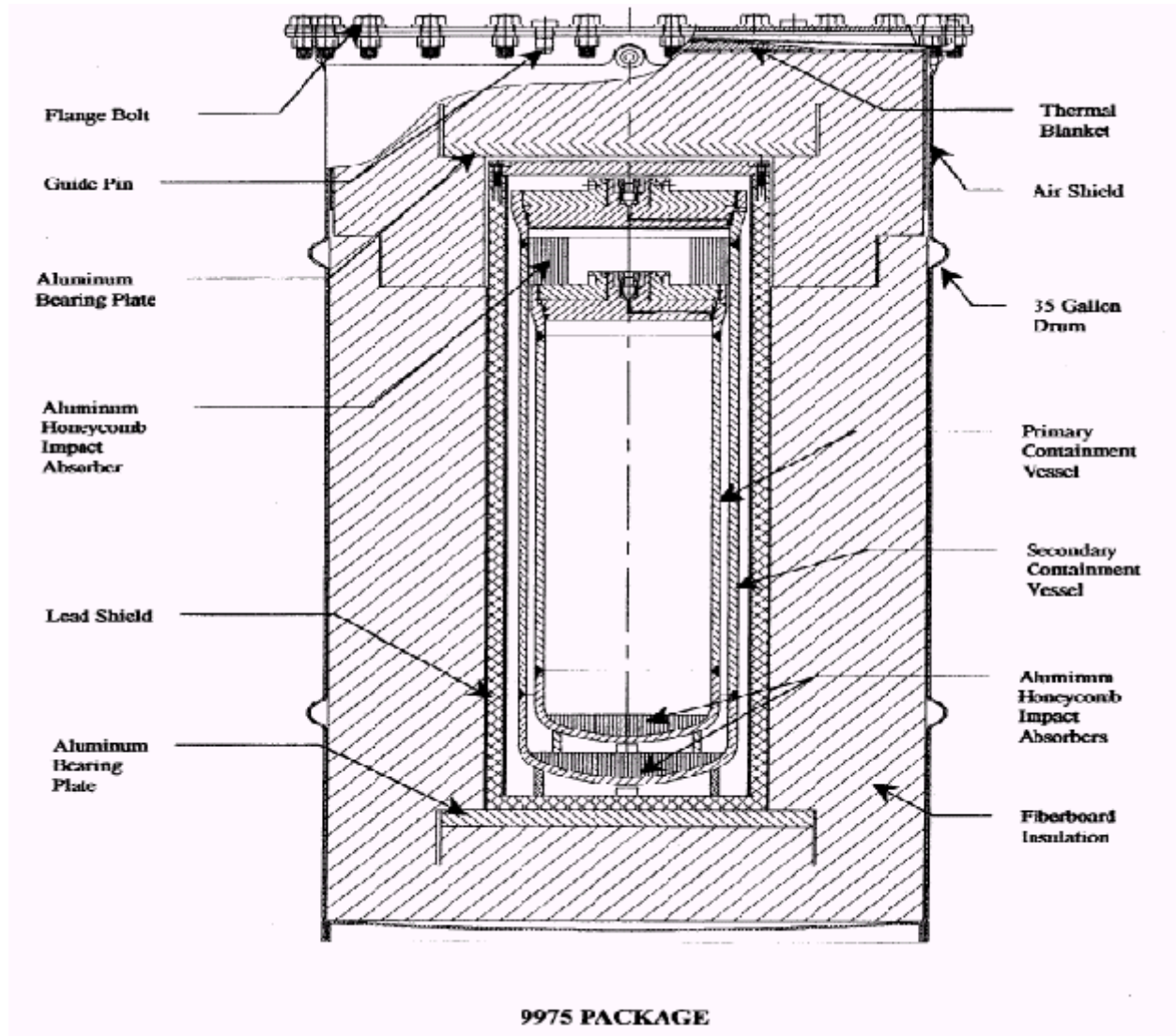

* from the DOE Certification of Compliance, USA/9975/B(M)F-85 (DOE), Revision 10

Appendix C (continued)

Cross Section View of a DOE-STD-3013 Container (typical with oxide convenience can)**

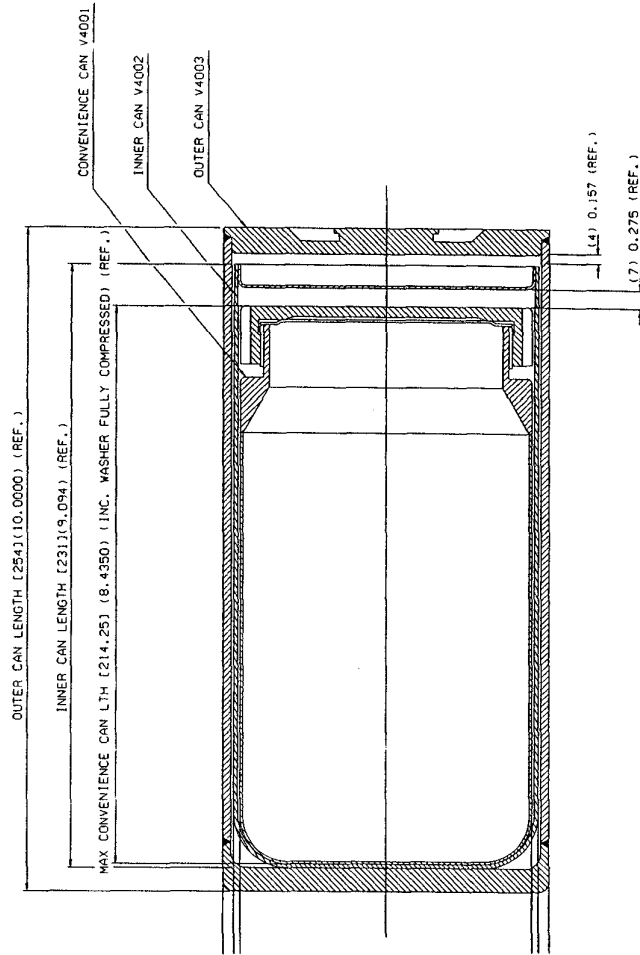

** from Savannah River Site drawing M PV F 0018, Plutonium Stabilization and Packaging System Assembly Storage Package

Appendix C (continued)

Cut-away View of a Type B 9975 Shipping Container with an Enclosed DOE-STD-3013 Container (with typical inner container for plutonium metal)***

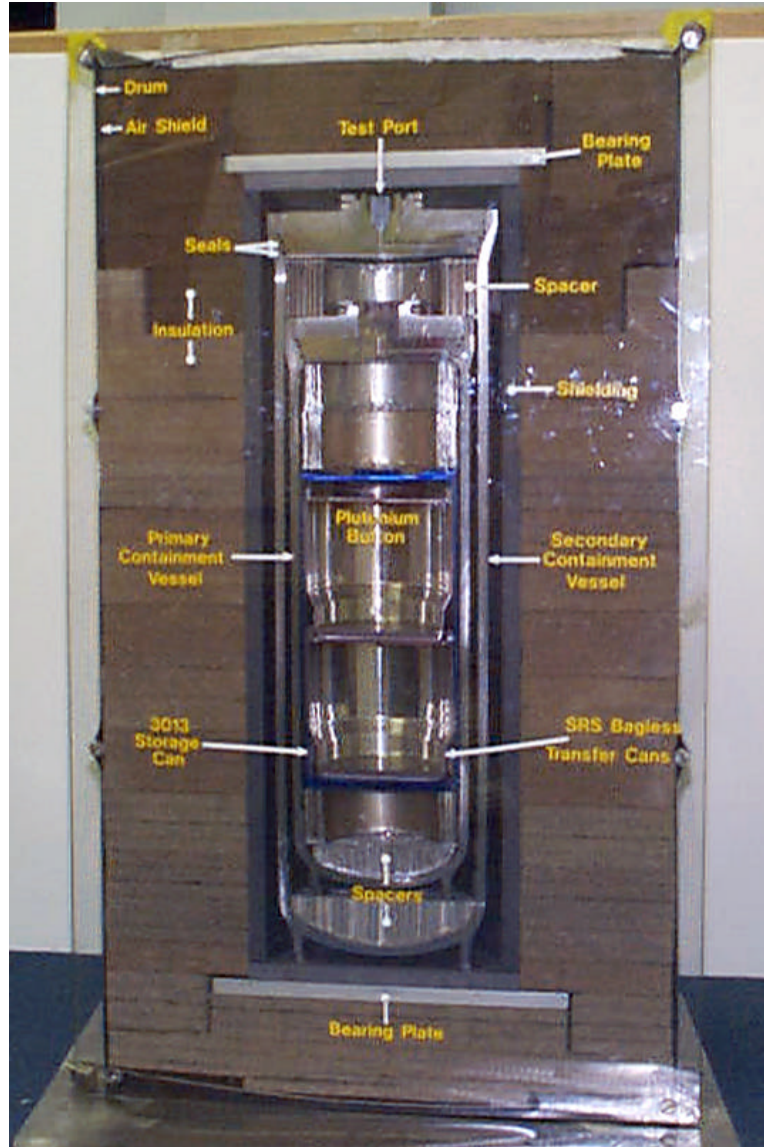

*** from SRS presentation by Kerry Dunn on July 10, 2003

Appendix C (continued)

Drawing of a Pipe Overpack Container (POC)****

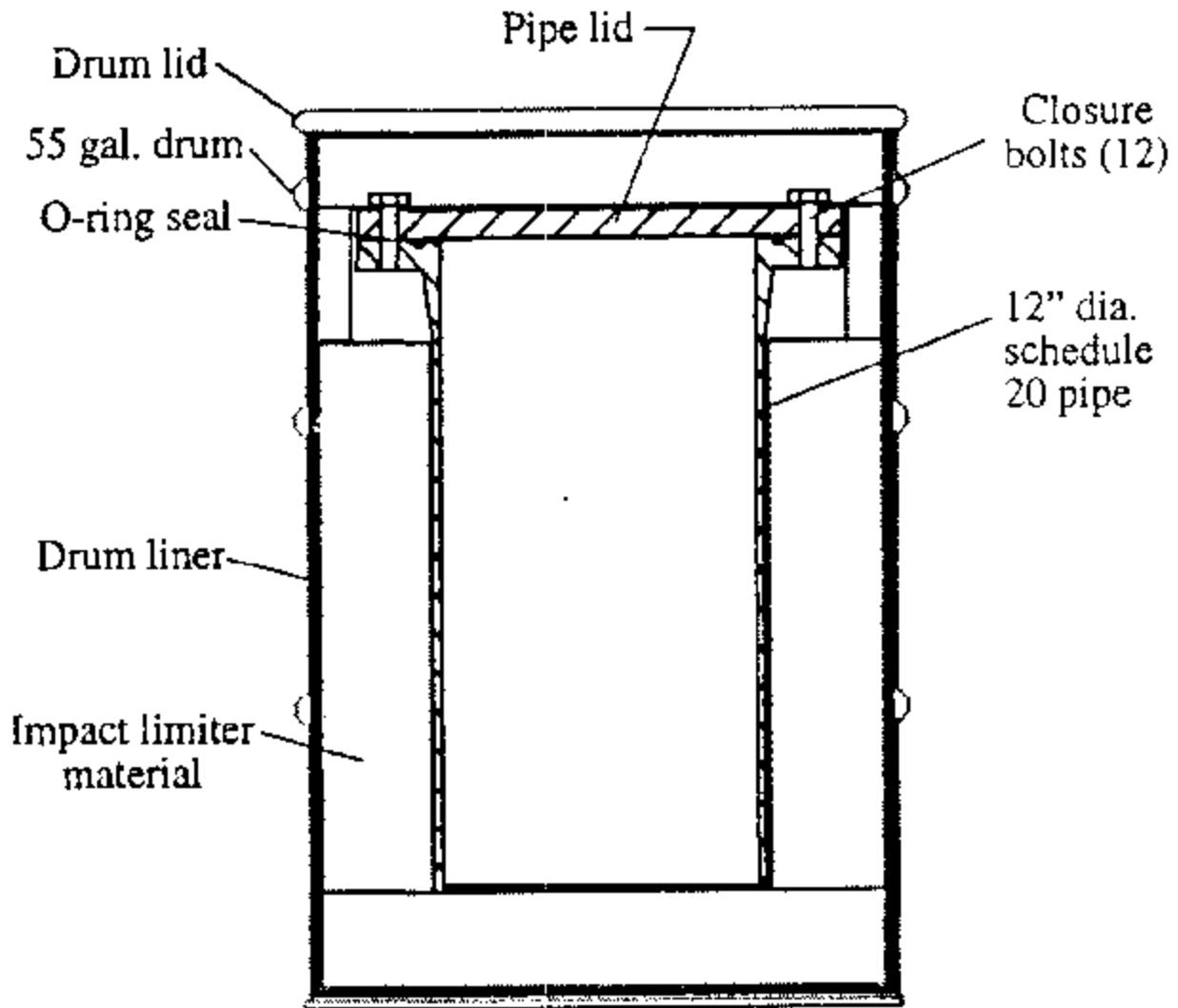

**** from WSRC report S-OSA-G-00009, dated July 17, 2002

APPENDIX D

PUBLIC LAW 107-314, SECTIONS 3181, 3182 and 3183

Subtitle E—Disposition of Weapons-Usable Plutonium at Savannah River, South Carolina

SEC. 3181. FINDINGS.

Congress makes the following findings:

(1) In September 2000, the United States and the Russian Federation signed a Plutonium Management and Disposition Agreement by which each agreed to dispose of 34 metric tons of weapons-grade plutonium.

(2) The agreement with Russia is a significant step toward safeguarding nuclear materials and preventing their diversion to rogue states and terrorists.

(3) The Department of Energy plans to dispose of 34 metric tons of weapons-grade plutonium in the United States before the end of 2019 by converting the plutonium to a mixed-oxide fuel to be used in commercial nuclear power reactors.

(4) The Department has formulated a plan for implementing the agreement with Russia through construction of a mixed-oxide fuel fabrication facility, the so-called MOX facility, and a pit disassembly and conversion facility at the Savannah River Site, Aiken, South Carolina.

(5) The United States and the State of South Carolina have a compelling interest in the safe, proper, and efficient operation of the plutonium disposition facilities at the Savannah River Site. The MOX facility will also be economically beneficial to the State of South Carolina, and that economic benefit will not be fully realized unless the MOX facility is built.

(6) The State of South Carolina desires to ensure that all plutonium transferred to the State of South Carolina is stored safely; that the full benefits of the MOX facility are realized as soon as possible; and, specifically, that all defense plutonium or defense plutonium materials transferred to the Savannah River Site either be processed or be removed expeditiously.

SEC. 3182. DISPOSITION OF WEAPONS-USABLE PLUTONIUM AT SAVANNAH RIVER SITE.

(a) PLAN FOR CONSTRUCTION AND OPERATION OF MOX FACILITY.—(1) Not later than February 1, 2003, the Secretary of Energy shall submit to Congress a plan for the construction and operation of the MOX facility at the Savannah River Site, Aiken, South Carolina.

(2) The plan under paragraph (1) shall include—

(A) a schedule for construction and operations so as to achieve, as of January 1, 2009, and thereafter, the MOX production objective, and to produce 1 metric ton of mixed-oxide fuel by December 31, 2009; and

(B) a schedule of operations of the MOX facility designed so that 34 metric tons of defense plutonium and defense plutonium materials at the Savannah River Site will be processed into mixed-oxide fuel by January 1, 2019.

(3)(A) Not later than February 15 each year, beginning in 2004 and continuing for as long as the MOX facility is in use, the Secretary shall submit to Congress a report on the implementation of the plan required by paragraph (1).

(B) Each report under subparagraph (A) for years before 2010 shall include—

(i) an assessment of compliance with the schedules included with the plan under paragraph (2); and

(ii) a certification by the Secretary whether or not the MOX production objective can be met by January 2009.

(C) Each report under subparagraph (A) for years after 2009 shall—

(i) address whether the MOX production objective has been met; and

(ii) assess progress toward meeting the obligations of the United States under the Plutonium Management and Disposition Agreement.

(D) Each report under subparagraph (A) for years after 2017 shall also include an assessment of compliance with the MOX production objective and, if not in compliance, the plan of the Secretary for achieving one of the following:

(i) Compliance with such objective.

(ii) Removal of all remaining defense plutonium and defense plutonium materials from the State of South Carolina.

(b) CORRECTIVE ACTIONS.—(1) If a report under subsection (a)(3) indicates that construction or operation of the MOX facility is behind the applicable schedule under subsection (a)(2) by 12 months or more, the Secretary shall submit to Congress, not later than August 15 of the year in which such report is submitted, a plan for corrective actions to be implemented by the Secretary to ensure that the MOX facility project is capable of meeting the MOX production objective by January 1, 2009.

(2) If a plan is submitted under paragraph (1) in any year after 2008, the plan shall include corrective actions to be implemented by the Secretary to ensure that the MOX production objective is met.

(3) Any plan for corrective actions under paragraph (1) or (2) shall include established milestones under such plan for achieving compliance with the MOX production objective.

(4) If, before January 1, 2009, the Secretary determines that there is a substantial and material risk that the MOX production objective will not be achieved by 2009 because of a failure to achieve milestones set forth in the most recent corrective action plan under this subsection, the Secretary shall suspend further transfers of defense plutonium and defense plutonium materials to be processed by the MOX facility until such risk is addressed and the Secretary certifies that the MOX production objective can be met by 2009.

(5) If, after January 1, 2009, the Secretary determines that the MOX production objective has not been achieved because of a failure to achieve milestones set forth in the most recent corrective action plan under this subsection, the Secretary shall suspend further transfers of defense plutonium and defense plutonium materials to be processed by the MOX facility until the Secretary certifies that the MOX production objective can be met.

(6)(A) Upon making a determination under paragraph (4) or (5), the Secretary shall submit to Congress a report on the options for removing from the State of South Carolina an amount of defense plutonium or defense

plutonium materials equal to the amount of defense plutonium or defense plutonium materials transferred to the State of South Carolina after April 15, 2002.

(B) Each report under subparagraph (A) shall include an analysis of each option set forth in the report, including the cost and schedule for implementation of such option, and any requirements under the National Environmental Policy Act of 1969 (42 U.S.C. 4321 et seq.) relating to consideration or selection of such option.

(C) Upon submittal of a report under paragraph (A), the Secretary shall commence any analysis that may be required under the National Environmental Policy Act of 1969 in order to select among the options set forth in the report.

(c) CONTINGENT REQUIREMENT FOR REMOVAL OF PLUTONIUM AND MATERIALS FROM SAVANNAH RIVER SITE.—If the MOX production objective is not achieved as of January 1, 2009, the Secretary shall, consistent with the National Environmental Policy Act of 1969 and other applicable laws, remove from the State of South Carolina, for storage or disposal elsewhere—

(1) not later than January 1, 2011, not less than 1 metric ton of defense plutonium or defense plutonium materials; and

(2) not later than January 1, 2017, an amount of defense plutonium or defense plutonium materials equal to the amount of defense plutonium or defense plutonium materials transferred to the Savannah River Site between April 15, 2002 and January 1, 2017, but not processed by the MOX facility.

(d) ECONOMIC AND IMPACT ASSISTANCE.—(1) If the MOX production objective is not achieved as of January 1, 2011, the Secretary shall, from funds available to the Secretary, pay to the State of South Carolina each year beginning on or after that date through 2016 for economic and impact assistance an amount equal to \$1,000,000 per day, not to exceed \$100,000,000 per year, until the later of—

(A) the date on which the MOX production objective is achieved in such year; or

(B) the date on which the Secretary has removed from the State of South Carolina in such year at least 1 metric ton of defense plutonium or defense plutonium materials.

(2)(A) If, as of January 1, 2017, the MOX facility has not processed mixed-oxide fuel from defense plutonium and defense plutonium materials in the amount of not less than—

(i) one metric ton, in each of any two consecutive calendar years; and

(ii) three metric tons total, the Secretary shall, from funds available to the Secretary, pay to the State of South Carolina for economic and impact assistance an amount equal to \$1,000,000 per day, not to exceed \$100,000,000 per year, until the removal by the Secretary from the State of South Carolina of an amount of defense plutonium or defense plutonium materials equal to the amount of defense plutonium or defense plutonium materials transferred to the Savannah River Site between April 15, 2002, and January 1, 2017, but not processed by the MOX facility.

(B) Nothing in this paragraph may be construed to terminate, supersede, or otherwise affect any other requirements of this section.

(3) If the State of South Carolina obtains an injunction that prohibits the Department from taking any action necessary for the Department to meet any deadline specified by this subsection, that deadline shall be extended for a period of time equal to the period of time during which the injunction is in effect.

(e) **FAILURE TO COMPLETE PLANNED DISPOSITION PROGRAM.**— If on July 1 each year beginning in 2020 and continuing for as long as the MOX facility is in use, less than 34 metric tons of defense plutonium or defense plutonium materials have been processed by the MOX facility, the Secretary shall submit to Congress a plan for—

(1) completing the processing of 34 metric tons of defense plutonium and defense plutonium material by the MOX facility; or

(2) removing from the State of South Carolina an amount of defense plutonium or defense plutonium materials equal to the amount of defense plutonium or defense plutonium materials transferred to the Savannah River Site after April 15, 2002, but not processed by the MOX facility.

(f) **REMOVAL OF MIXED-OXIDE FUEL UPON COMPLETION OF OPERATIONS OF MOX FACILITY.**—If, one year after the date on which operation of the MOX facility permanently ceases, any mixed-oxide fuel remains at the Savannah River Site, the Secretary shall submit to Congress—

(1) a report on when such fuel will be transferred for use in commercial nuclear reactors; or

(2) a plan for removing such fuel from the State of South Carolina.

(g) **DEFINITIONS.**—In this section:

(1) **MOX PRODUCTION OBJECTIVE.**—The term “MOX production objective” means production at the MOX facility of mixed-oxide fuel from defense plutonium and defense plutonium materials at an average rate equivalent to not less than one metric ton of mixed-oxide fuel per year. The average rate shall be determined by measuring production at the MOX facility from the date the facility is declared operational to the Nuclear Regulatory Commission through the date of assessment.

(2) **MOX FACILITY.**—The term “MOX facility” means the mixed-oxide fuel fabrication facility at the Savannah River Site, Aiken, South Carolina.

(3) **DEFENSE PLUTONIUM; DEFENSE PLUTONIUM MATERIALS.** —The terms “defense plutonium” and “defense plutonium materials” mean weapons-usable plutonium.

SEC. 3183. STUDY OF FACILITIES FOR STORAGE OF PLUTONIUM AND PLUTONIUM MATERIALS AT SAVANNAH RIVER SITE.

(a) **STUDY.**—The Defense Nuclear Facilities Safety Board shall conduct a study of the adequacy of the K-Area Materials Storage facility (KAMS), and related support facilities such as Building 235–F, at the Savannah River Site, Aiken, South Carolina, for the storage of defense plutonium and defense plutonium materials in connection with the disposition program provided in section 3182 and in connection with the amended Record of Decision of the Department of Energy for fissile materials disposition.

(b) **REPORT.**—Not later than one year after the date of the enactment of this Act, the Defense Nuclear Facilities Safety Board shall submit to Congress and the Secretary of Energy a report on the study conducted under subsection (a).

(c) **REPORT ELEMENTS.**—The report under subsection (b) shall—

(1) address—

(A) the suitability of KAMS and related support facilities for monitoring and observing any defense plutonium or defense plutonium materials stored in KAMS;

(B) the adequacy of the provisions made by the Department for remote monitoring of such defense plutonium and defense plutonium materials by way of sensors and for handling of retrieval of such defense plutonium and defense plutonium materials; and

(C) the adequacy of KAMS should such defense plutonium and defense plutonium materials continue to be stored at KAMS after 2019; and

(2) include such proposals as the Defense Nuclear Facilities Safety Board considers appropriate to enhance the safety, reliability, and functionality of KAMS.

(d) **REPORTS ON ACTIONS ON PROPOSALS.**—Not later than 6 months after the date on which the report under subsection (b) is submitted to Congress, and every year thereafter, the Secretary and the Board shall each submit to Congress a report on the actions taken by the Secretary in response to the proposals, if any, included in the report.

GLOSSARY OF ACRONYMS

ACI	American Concrete Institute	N/A	not applicable
ALARA	as-low-as-reasonably-achievable	NDE	nondestructive evaluation
APSF	Actinide Packaging and Storage Facility	NEC	National Electric Code
Board	Defense Nuclear Facilities Safety Board	NFPA	National Fire Protection Association
CFM	cubic feet per minute	NNSA	National Nuclear Security Administration
CFR	Code of Federal Regulations	PA	public address
CMMS	computerized maintenance management system	PC	Performance Category
CSMO	Central Scrap Management Office	PDCF	Pit Disassembly and Conversion Facility
D/C	demand-to-capacity	POC	pipe overpack container
DE	destructive evaluation	psi	pounds per square inch
DNFSB	Defense Nuclear Facilities Safety Board	Pu	Plutonium
DOE	Department of Energy	PuFF	Plutonium Fuel Form Facility
DOE-SR	Savannah River Operations Office	RFETS	Rocky Flats Environmental Technology Site
DOT	Department of Transportation	SCC	stress corrosion cracking
DSA	documented safety analysis	SEP	Systematic Evaluation Program
ECAD	Electronic Characterization and Diagnostics	SNM	special nuclear material
FHA	fire hazards analysis	S/RID	Standards/Requirements Identification Document
HEPA	high-efficiency particulate air	SRS	Savannah River Site
HEU	highly-enriched uranium	SRTC	Savannah River Technology Center
IEEE	Institute of Electrical and Electronics Engineers	SSC	structures, systems, and components
I&C	instrumentation and control	SSI	soil-structure interaction
KAMS	K-Area Materials Storage	TSR	technical safety requirement
MSA	Material Storage Area	U	Uranium
MORT	management oversight risk tree	WSRC	Westinghouse Savannah River Company
MOX	mixed-oxide	235-F	Building 235-F

REFERENCES

1. Sena, R. F., Director, Nuclear Materials Stewardship Project Office, U.S. Department of Energy Memorandum, *Savannah River Plutonium Storage Study Final Report*, November 30, 2000.
2. Conway, J. T., Chairman, Defense Nuclear Facilities Safety Board, Letter to S. Abraham, Secretary, U.S. Department of Energy, Washington, D.C., March 23, 2001.
3. Roberson, J. H., Assistant Secretary for Environmental Management, U.S. Department of Energy, Memorandum for Distribution, *Office of Environmental Management Program Objectives for the Disposal and Consolidation of Nuclear Materials*, October 10, 2002.
4. Westinghouse Savannah River Company, Memorandum, *Nuclear Materials Management Department Off-Site Special Nuclear Material Receipt Plan*, January 20, 2003.
5. Conway, J. T., Chairman, Defense Nuclear Facilities Safety Board, Letter to S. Abraham, Secretary, U.S. Department of Energy, Washington, D.C., June 12, 2003.
6. Conway, J. T., Chairman, Defense Nuclear Facilities Safety Board, Letter to J. H. Roberson, Assistant Secretary for Environmental Management, U.S. Department of Energy, Washington, D.C., July 10, 2003.
7. Abraham, S., Secretary, U.S. Department of Energy, Letter to J. T. Conway, Chairman, Defense Nuclear Facilities Safety Board, Washington, D.C., November 10, 2003.